

Application

Model RBDR-50 is a round remote powered balancing damper designed to regulate the flow of air in a HVAC system. This balancing damper is ideal for applications where it is difficult to get access to manually adjust the dampers and balance the airflow.

The 'EZ Balance' hand held remote (equipped with 9 volt power supply) operates the damper actuator when connected to the diffuser connector or wall/ceiling plate.

Ratings

Pressure

1 in. wg (0.25 kPa) - pressure differential

Velocity

Operational rated up to 2000 fpm (10.2 m/s)

Temperature

Maximum: 180°F (82°C)

Construction

	Standard
Frame Material	Galvanized Steel
Frame Thickness	20 ga. (1mm)
Blade Material	Galvanized Steel
Blade Thickness	20 ga. (1mm)
Axles	3/8 in. sq. (10mm) Plated Steel
Bearings	Synthetic (acetal) Sleeve Type
Operator	9 Volt Actuator

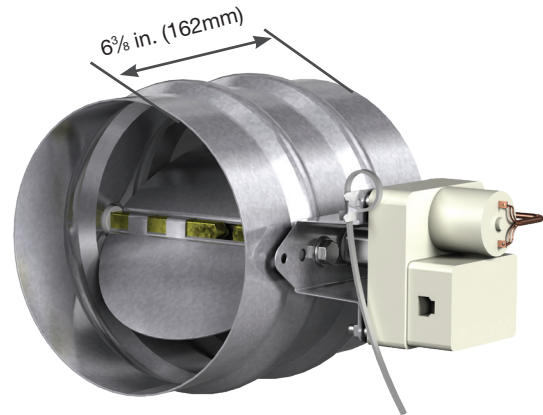

Diameter dimension is furnished approximately 1/8 in. (3mm) undersize.

Size Limitations

Diameter	Minimum Size	Maximum Size
Inches	4	24
mm	102	610

Accessories

- Diffuser connectors
- Single gang wall plates with ports (1,2, 3, 4 or 6 port)
 - Colors: white, or stainless steel
- Round wall/ceiling mounting plate with one port
- Single gang outlet box
- 'EZ Balance' remote control device (9 volt battery and 5 foot (1524mm) of cable included)
- 5, 14, 25 or 50 foot (1524, 4267, 7620 or 15,240mm) plenum rated cable
- Cable connectors

Wall plates with ports

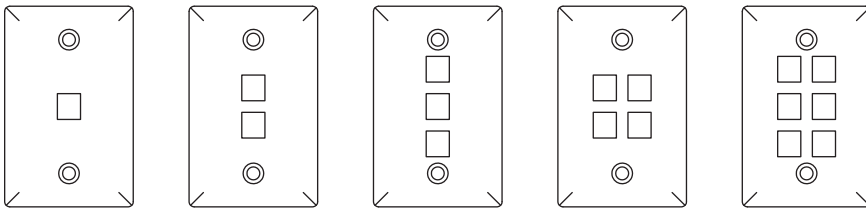

One Port

Two Ports

Three Ports

Four Ports

Six Ports

White wall plate dimension is 3 1/4 in. x 4 3/4 in. (83mm x 121mm).

Stainless steel wall plate dimension is 2 3/4 in. x 4 1/2 in. (70mm x 114mm).

Single gang box



Round wall/ceiling plate



3 1/4 in. (83mm) diameter

EZ Balance remote

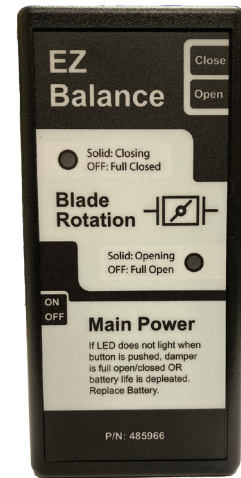

Dimensional Drawings

anti strain wire tie to secure cable to actuator bracket

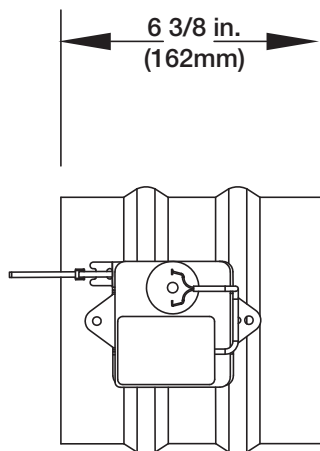

Side View

Actuator factory mounted

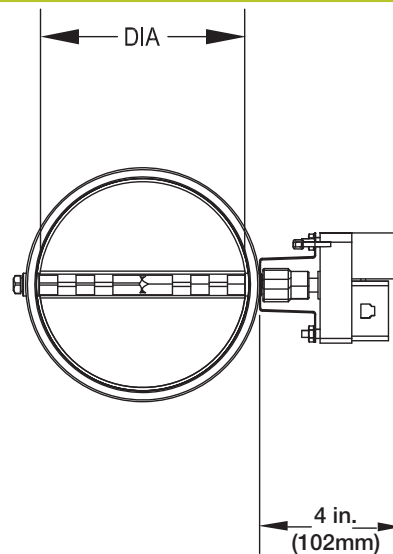

Front View

Actuator factory mounted

Note:

All wire connections are made with prewired RJ11 plugs and socket. No additional wiring or tools required.

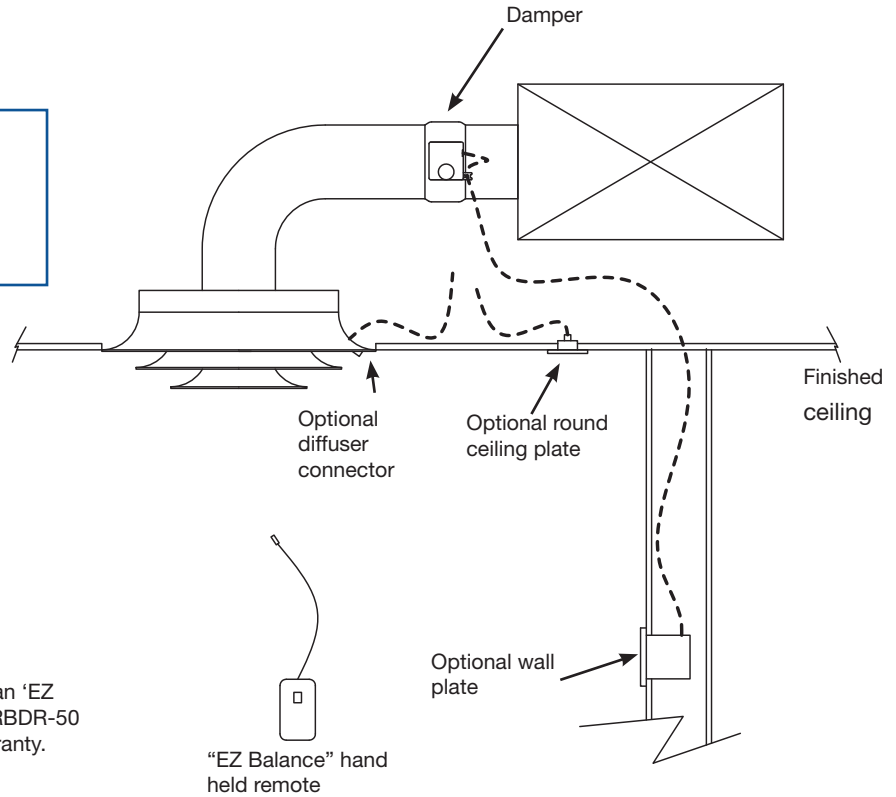

Note:

Utilizing any controller other than 'EZ Balance' remote to adjust the RBDR-50 damper voids the actuator warranty.

Document Links



[INSTALLATION](#)



[CATALOG](#)



[SPECIFICATIONS](#)



[SELECTION GUIDE](#)



[RBD ACCESSORIES](#)



[WARRANTY](#)