

### Application

The RRL Option replaces the fusible link on a combination fire smoke damper with an electric sensor (thermostat). The sensor has a fixed temperature setting (usually 165° F [74°C]) and performs the same function as the fusible link that it replaces. The sensor interrupts power to the actuator and the actuator's spring return mechanism causes the damper to close.

The sensor is of the manual reset type and can be reset after the temperature has cooled down below the sensor set point.

Before resetting any sensor, a careful inspection of the damper and sensor should be made as exposure to actual fire conditions may render these devices unusable.

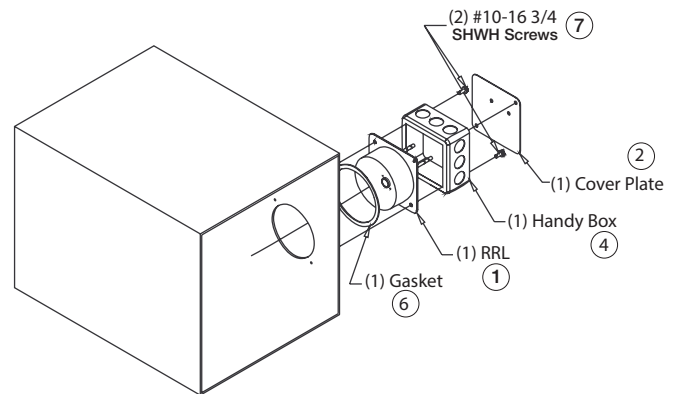
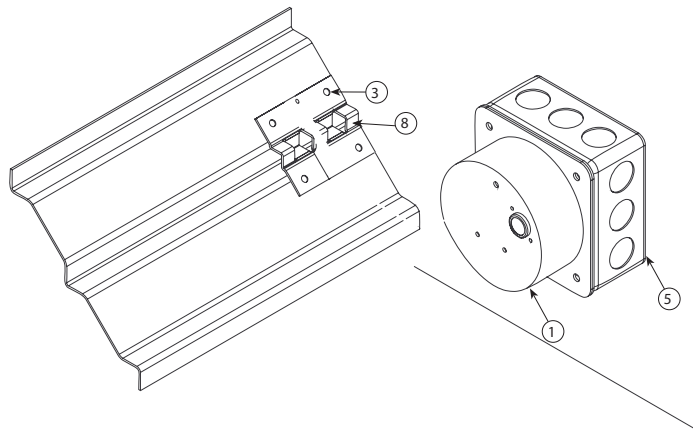

Item Number	Part Number	Qty.	Description
1	820734 (165°) 821278 (212°) 824671 (250°) 824672 (350°)	1	RRL Switch Box
2	658593	1	4 in. x 4 in. Cover Plate
3	415555	4	self-drilling Screws, HWH, #10-16x.5
4	380864	1	4 in. x 4 in. Handy Box
5	460632	1	Label
6	370119	1	EPDM Gasket
7	415926*	2	TCS, SHWH, #10-16x.75 Screws
8	658594	4	Blade Clip

\* Can also use equivalent #10 nut and bolt combination such as 415416 (STH #10-32x.5) and 415385 (Hex nut #10-32).

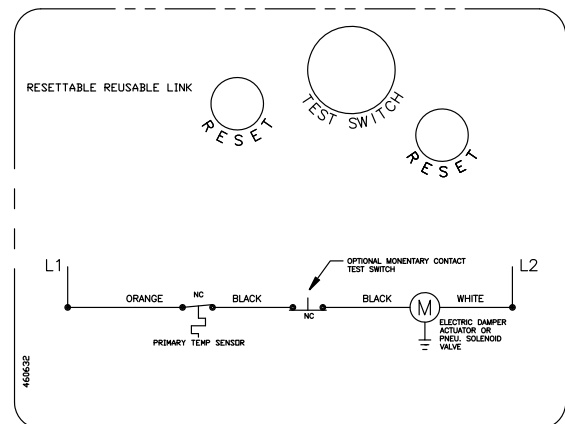

WIRING DIAGRAM