



Model SEFSDR-511

Round Combination Fire Smoke Dampers
UL 555 1½ Hour Fire Resistance Rating
UL 555 Leakage Class I

Application

Model SEFSDR-511 is a combination fire smoke damper constructed out of 316 stainless steel with round style blades. The SEFSDR-511 has been qualified to 4,000 fpm (20.3 m/s) and 4 in. wg (1 kPa) for operation and dynamic closure in emergency fire smoke situations.

Ratings

UL 555 Fire Resistance Rating

Fire Rating: 1½ hour

Dynamic Closure Rating: Actual ratings are size dependent

Velocity: Up to 4,000 fpm (20.3 m/s)

Pressure: Up to 4 in. wg

UL 555S Leakage Rating

Leakage Class: I

Operational Rating: Actual ratings are actuator dependent

Velocity: Up to 4,000 fpm (20.3 m/s)

Temperature: Up to 350°F (177°C) - depending on actuator

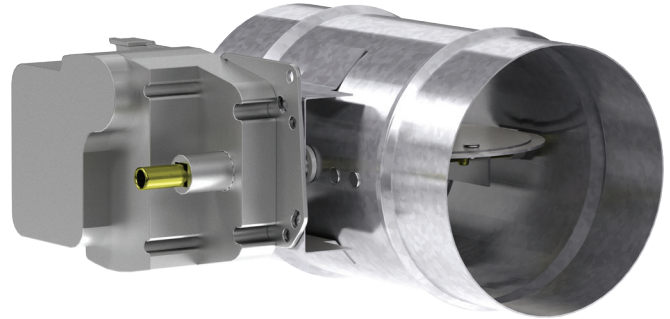

* The diameter dimension furnished approximately 1/8 in (3mm) undersize.

Model SEFSDR-511 meets the requirements for smoke dampers established by:

National Fire Protection Association
 NFPA Standards 80, 90A, 92, 101 & 105
International Building Codes (IBC)

California State Fire Marshal

Listing #: 3225-0981: 0112 (fire)

Listing #: 3230-0981: 0113 (smoke)

Underwriters Laboratories Standard 555
 (Listing R13317)

Construction	Standard	Optional
Frame Material	316SS	-
Frame Material Thickness	20 ga. (1mm)	16 ga. (1.5mm) 14 ga. (2mm)
Blade Material	Double skin 316SS	-
Blade Seal	Silicone	
Blade Thickness	14 ga. (2mm)	-
Axle Bearings	316SS	-
Axle Material	½ in. (13mm) 316SS	-
Closure Device	Fusible Link	RRL, RRL/OCI, TOR
Closure Temperature	165° (74°C)	212°F (100°C), 250°F (121°C), 286°F (141°C), 350°F (177°C)

Diameter	Minimum	Maximum
in. (mm)	6 (152)	24 (610)

Features

- OCI (Open Closed Indication switches - not 316SS)
- Electric actuators
- One retainer plate required, additional plate available
- Momentary switch



See complete marking on product.

UL 555 & UL 555S

Classification R13317

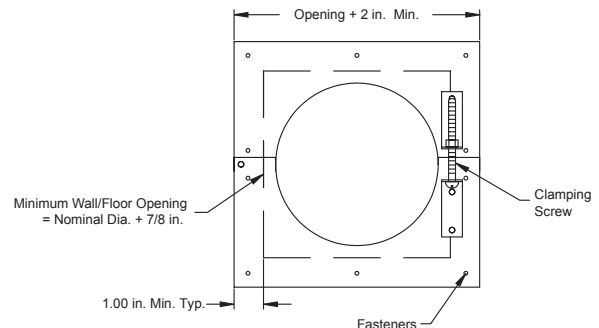

Installation instructions available at www.greenheck.com.

Pressure Drop Data

This pressure drop testing was conducted in accordance with AMCA Standard 500-D using the configuration shown. All data has been corrected to represent standard air at a density of .075 lb/ft³ (1.201 kg/m³). Actual pressure drop found in any HVAC system is a combination of many factors. This pressure drop information along with an analysis of other system influences should be used to estimate actual pressure losses for a damper installed in a given HVAC system.

AMCA Test Figure

Figure 5.3 illustrates a fully ducted damper. This configuration has the lowest pressure drop of the three test configurations because entrance and exit losses are minimized by straight duct runs upstream and downstream of the damper.

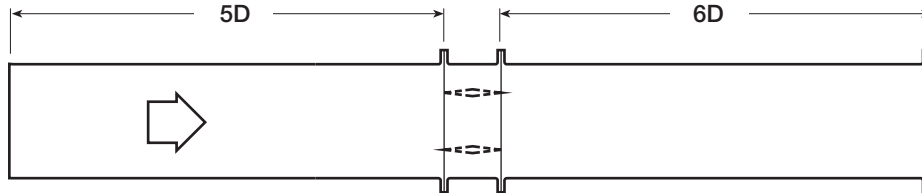

VELOCITY VS. PRESSURE DROP

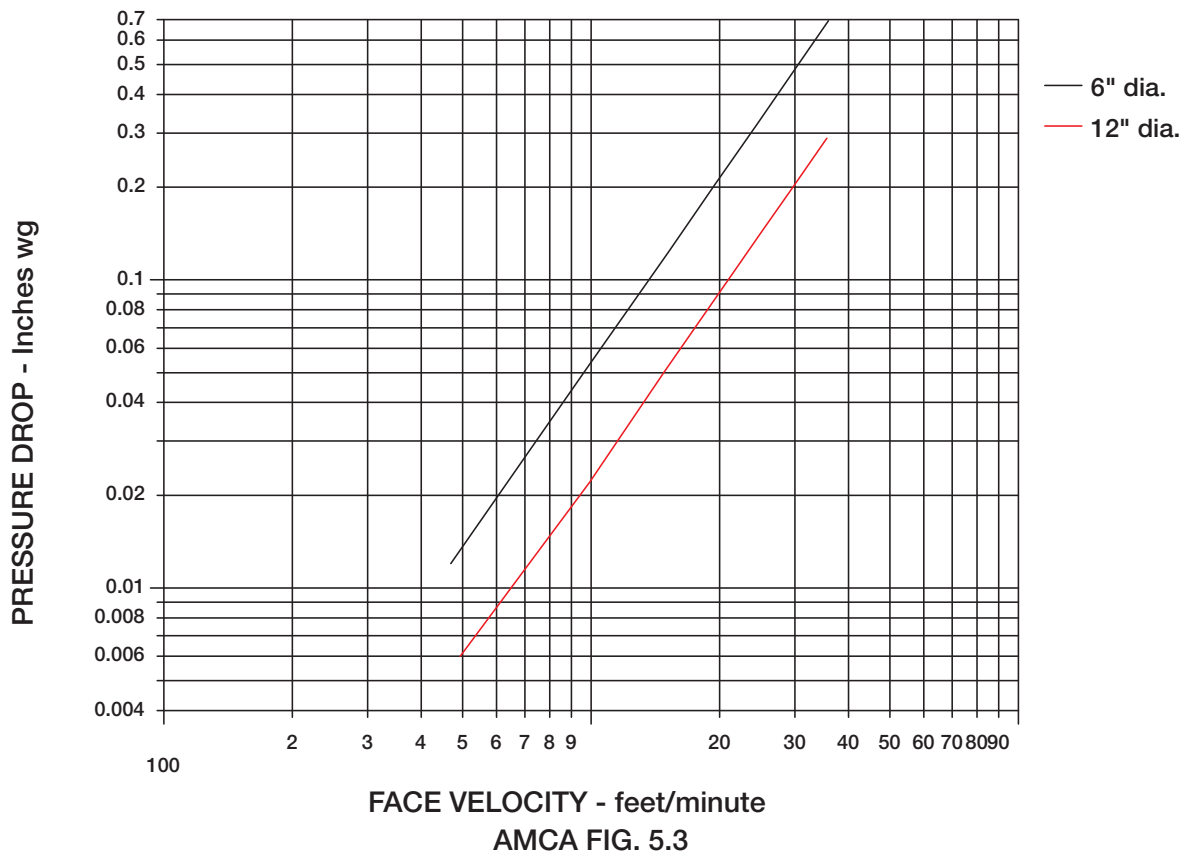

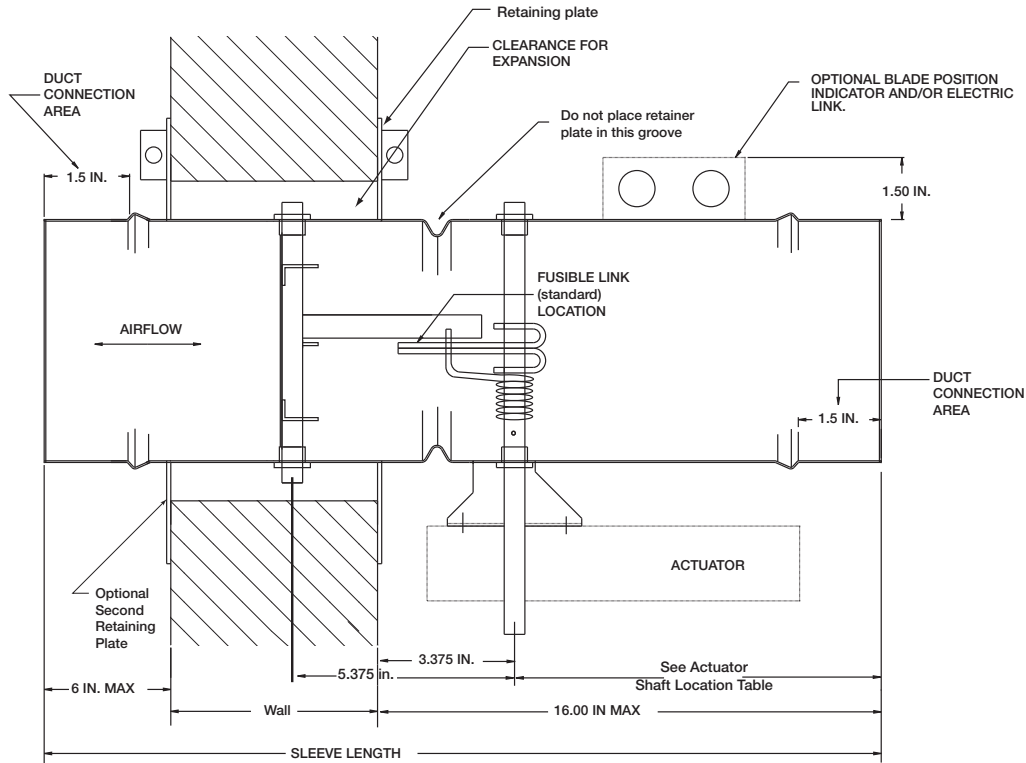

TOP VIEW OF DAMPER

Actuator Shaft Location (in inches)				
Control Device	Diameter (in inches)			
	≥ 6 to ≤10 ¹ / ₈	>10 ¹ / ₈ to ≤11 ¹ / ₈	>11 ¹ / ₈ to ≤14 ¹ / ₈	>14 ¹ / ₈
Fusible Link	3 ¹ / ₁₆	3 ¹ / ₁₆	3 ¹ / ₁₆	3 ¹ / ₁₆
RRL	5 ¹¹ / ₁₆	4 ¹¹ / ₁₆	4 ¹¹ / ₁₆	4 ¹¹ / ₁₆
RRL/OCI	7 ⁷ / ₁₆	7 ⁷ / ₁₆	7 ⁷ / ₁₆	7 ⁷ / ₁₆
TOR	7 ⁷ / ₁₆	7 ⁷ / ₁₆	7 ⁷ / ₁₆	7 ⁷ / ₁₆

Specifications

True round smoke dampers meeting the following specifications shall be furnished and installed where shown on plans and/or as described in schedules.

Dampers shall meet the requirements of the latest edition of NFPA 80, 90A, 92, 101, and 105. Dampers shall be tested, rated, and labeled in accordance with the latest edition of UL Standards 555 and 555S. Dampers shall have a UL 555 fire rating of 1½ hours.

Each damper/actuator combination shall have a UL 555S elevated temperature rating of 250° F (121°C) minimum and shall be operational and dynamic rated to operate at maximum design air flow at its installed location. Each damper shall be supplied with an appropriate actuator installed by the damper manufacturer at the time of damper fabrication. Damper actuator shall be (specifier select one of the following) electric type for 120, 24, or 230 volt operation or pneumatic type for 25 psi minimum (30 psi maximum) operation.

Damper shall be constructed of 20 ga. (1mm) 316 stainless steel frame/sleeve; blade constructed of double skin 316 stainless steel round style blade; silicone rubber blade seal; ½ in. 316 stainless steel axles and bearings. Damper is provided with one retainer plate.

Damper must be rated for mounting vertically (with blades running horizontal) or horizontally and be UL 555S rated for leakage and airflow in either direction through the damper. Each damper shall be supplied with a 165°F (74°C) fusible link. Testing and ratings to be in accordance with AMCA standard 500-D.

Basis of design is model SEFSDR-511.

