

Application

The VCD-34V series is a low leakage control damper with vertical thermally insulated blades. The VCD-34V is intended for application in medium pressure and velocity systems.

This model is also IECC (International Energy Conservation Code) compliant with a leakage rating of 3 cfm/ft² at 1 in. wg (55 cmh/m² at .25 kPa) or less.

Damper Ratings

Velocity

Up to 4000 fpm (20.3 m/s)

Leakage

Class 1A at 1 in. wg (.25 kPa)

Class 1 at 4 in. - 8 in. wg (1 kPa - 2 kPa)

Pressure

Up to 8 in. wg (2 kPa) pressure differential

For pressures greater than 8 in wg, consult factory.

Temperature

-40°F to 250°F (-40°C to 121°C). Consult factory for higher temperatures.



*W&H dimension furnished approximately ¼ in. (6mm) undersize.

Size Limitations

W x H	Minimum Size	Maximum Size	
		Single Section	Multiple Section
Inches	6 x 10	74 x 60	148 x 120
mm	152 x 254	1880 x 1524	3759 x 3048

Construction

	Standard	Optional
Frame Material	Galvanized Steel	304SS
Frame Thickness	16 ga. (1.5 mm)	12 ga. (2.7 mm)*
Frame Type	5 in. x 1 in. (127mm x 25mm) hat channel	Single flange, Reversed flange, Double flange
Blade Material	Galvanized steel	304SS
Blade Thickness	2 skins of 20 ga. (1mm)	-
Blade Type	Insulated Airfoil	-
Blade Action	Opposed	Parallel
Linkage	Plated steel out of airstream	316SS
Axle Bearings	Synthetic (acetal)	316SS
Axle Material	Plated steel	316SS
Blade Seals	TPE	Silicone
Jamb Seals	Stainless Steel	-

*When 12 ga. frame is selected and the damper height is less than 17 inches, low profile top and bottom frame members are utilized. These low profile frame members will be made from 16 ga. material.

Blade Operation

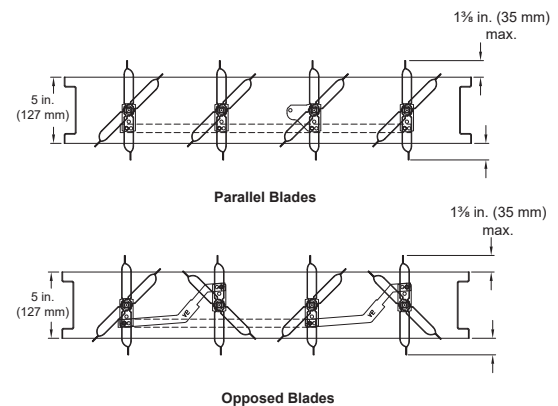

Notes:

- Low profile head and sill are used on sizes less than 17 in. (432mm) high
- Electric actuator and manual quadrant available. Factory supplied actuators are sized for 1500 fpm (7m/s) and fully closed differential pressure of 2 in. wg (.5 kPa). contact factory for actuator sizing on applications exceeding those limits. Actuators (when supplied) are mounted on the top or bottom.
- In applications where airflow could be uneven, such as a discharge fan, it is imperative to verify that at no point the maximum velocity exceeds the damper's cataloged velocity.

Options

- Actuators (24V, 120V, manual, pull chain)
- Actuator mounting (external, external kit (field assembly), internal)
- Flanges
- Multi-section fastening
- NEMA enclosures (3, 4, 4X, 7)
- R Transition
- [Retaining angles](#)
- Sleeves
- Transformers

Flange options

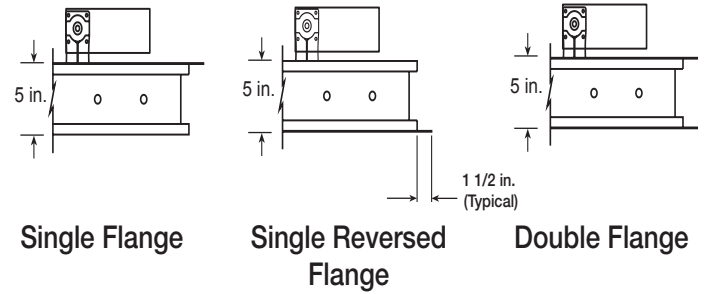

Shown with optional internally mounted actuator.

Document Links



[INSTALLATION](#)



[CATALOG](#)



[SELECTION GUIDE](#)



[SPECIFICATIONS](#)



[WARRANTY](#)

AMCA Certified Pressure Drop Data

AMCA 5.2

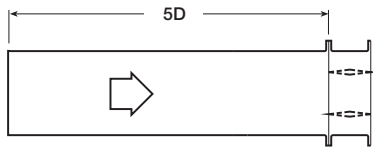

12 in. x 12 in. (305mm x 305mm)

Velocity (fpm)	Pressure Drop (in. wg)
500	0.01
1000	0.05
1500	0.11
2000	0.19
2500	0.29
3000	0.41
3500	0.55
4000	0.72

24 in. x 24 in. (610mm x 610mm)

Velocity (fpm)	Pressure Drop (in. wg)
500	0.01
1000	0.03
1500	0.06
2000	0.10
2500	0.16
3000	0.23
3500	0.30
4000	0.40

36 in. x 36 in. (914mm x 914mm)

Velocity (fpm)	Pressure Drop (in. wg)
500	0.01
1000	0.02
1500	0.05
2000	0.09
2500	0.14
3000	0.19
3500	0.27
4000	0.35

48 in. x 12 in. (1219mm x 305mm)

Velocity (fpm)	Pressure Drop (in. wg)
500	0.01
1000	0.04
1500	0.08
2000	0.15
2500	0.22
3000	0.32
3500	0.43
4000	0.56

12 in. x 48 in. (305mm x 1219mm)

Velocity (fpm)	Pressure Drop (in. wg)
500	0.01
1000	0.03
1500	0.07
2000	0.12
2500	0.18
3000	0.26
3500	0.36
4000	0.47

AMCA 5.3

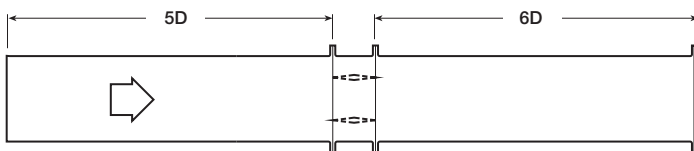

12 in. x 12 in. (305mm x 305mm)

Velocity (fpm)	Pressure Drop (in. wg)
500	0.01
1000	0.03
1500	0.08
2000	0.13
2500	0.20
3000	0.29
3500	0.40
4000	0.51

24 in. x 24 in. (610mm x 610mm)

Velocity (fpm)	Pressure Drop (in. wg)
500	0.01
1000	0.02
1500	0.04
2000	0.07
2500	0.11
3000	0.16
3500	0.21
4000	0.28

36 in. x 36 in. (914mm x 914mm)

Velocity (fpm)	Pressure Drop (in. wg)
500	0.01
1000	0.02
1500	0.03
2000	0.06
2500	0.09
3000	0.13
3500	0.19
4000	0.25

48 in. x 12 in. (1219mm x 305mm)

Velocity (fpm)	Pressure Drop (in. wg)
500	0.01
1000	0.03
1500	0.07
2000	0.12
2500	0.18
3000	0.26
3500	0.36
4000	0.46

12 in. x 48 in. (305mm x 1219mm)

Velocity (fpm)	Pressure Drop (in. wg)
500	0.01
1000	0.03
1500	0.06
2000	0.10
2500	0.16
3000	0.22
3500	0.30
4000	0.39

AMCA 5.5

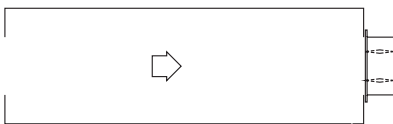

12 in. x 12 in. (305mm x 305mm)

Velocity (fpm)	Pressure Drop (in. wg)
500	0.03
1000	0.12
1500	0.27
2000	0.48
2500	0.74
3000	1.07
3500	1.46
4000	1.91

24 in. x 24 in. (610mm x 610mm)

Velocity (fpm)	Pressure Drop (in. wg)
500	0.03
1000	0.11
1500	0.26
2000	0.45
2500	0.71
3000	1.02
3500	1.40
4000	1.89

36 in. x 36 in. (914mm x 914mm)

Velocity (fpm)	Pressure Drop (in. wg)
500	0.02
1000	0.09
1500	0.21
2000	0.38
2500	0.58
3000	0.85
3500	1.15
4000	1.52

48 in. x 12 in. (1219mm x 305mm)

Velocity (fpm)	Pressure Drop (in. wg)
500	0.03
1000	0.11
1500	0.24
2000	0.43
2500	0.67
3000	0.96
3500	1.31
4000	1.71

12 in. x 48 in. (305mm x 1219mm)

Velocity (fpm)	Pressure Drop (in. wg)
500	0.03
1000	0.11
1500	0.24
2000	0.44
2500	0.68
3000	0.97
3500	1.32
4000	1.73

AMCA Certified Leakage

Air leakage is based on operation between 32°F (0°C) and 120°F (49°C).

Tested for leakage in accordance with ANSI/AMCA Standard 500-D, Figure 5.5.

Tested for air performance in accordance with ANSI/AMCA Standard 500-D, Figures 5.2, 5.3 and 5.5.

Torque

Data are based on a torque of 7.0 in.lb./ft² (0.79 N·m) applied to close and seat the damper during the test.

VCD-34V	Leakage Class*		
Maximum Damper Width	1 in. wg (0.25 kPa)	4 in. wg (1 kPa)	8 in. wg (2 kPa)
60 in. (1524mm)	1A	1	1

*Leakage Class Definitions

The maximum allowable leakage is defined by AMCA as the following:

- Leakage Class 1A - 3 cfm/ft² at 1 in. wg (class 1A is only defined at 1 in. wg).
- Leakage Class 1
 - 4 cfm/ft² at 1 in. wg
 - 8 cfm/ft² at 4 in. wg
 - 11 cfm/ft² at 8 in. wg
 - 12.6 cfm/ft² at 10 in. wg

Velocity Limitations

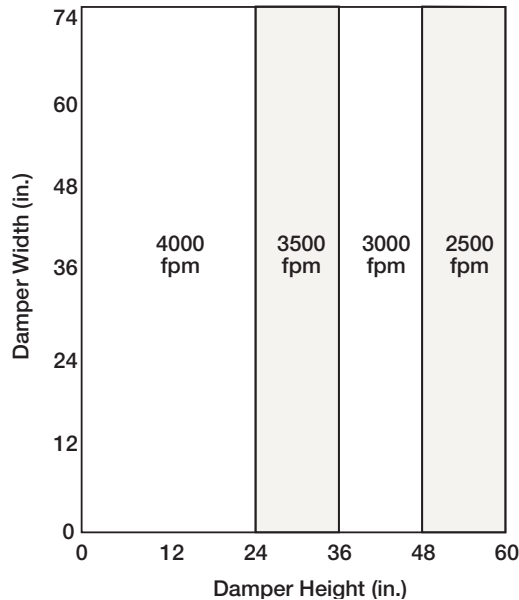

Temperature Limitations

Blade Seal	Temperature Range
TPE	-10°F to 180°F (-23°C to 82°C)
Silicone	-40°F to 250°F (-40°C to 121°C)
No Seal	-40°F to 250°F (-40°C to 121°C)

Space Envelopes

On dampers less than 18 in. (457mm) high, actuators may also require clearances above and/or below the damper frame. “B” and “T” dimensions are worst case clearance requirements for some dampers less than 18 in. (457mm) high. All damper sizes under 18 in. (457mm) high do not require these worst case clearances. If space availability above or below the damper is limited, each damper size should be individually evaluated.

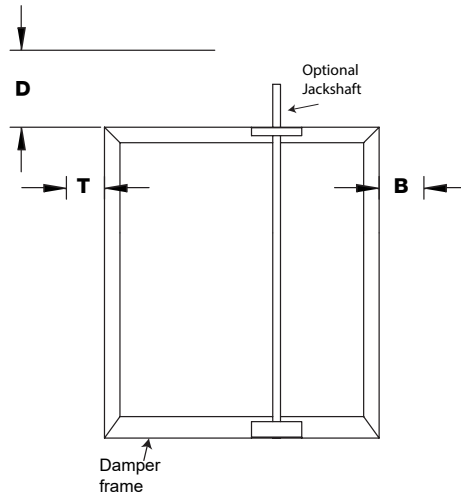

Actuator Type/Model	Height	T	B	D
	Inches	Inches		
AFBUP (-S) and FSNF Series, Belimo MSxx20 Series, Honeywell	≥6 to <10	0	12 ³ / ₄	6 ¹ / ₄
	≥10 to <18	0	2	6 ¹ / ₄
	≥18	0	0	6 ¹ / ₄
FSLF, LF and TFB Series, Belimo	≥6 to <10	0	3 ¹ / ₂	6 ¹ / ₄
	≥10	0	0	6 ¹ / ₄
MSxx04 & MSxx09 Series, Honeywell	≥6 to <9	0	4 ³ / ₄	6 ¹ / ₄
	≥9	0	0	6 ¹ / ₄
MS75xx Series, Honeywell	≥6 to <10	0	12 ³ / ₄	6 ¹ / ₄
	≥10 to <18	0	7	6 ¹ / ₄
	≥18	0	0	6 ¹ / ₄
GRD and GVD Series, Siemens	≥6 to <10	0	12 ³ / ₄	6 ¹ / ₄
	≥10 to <18	0	2	6 ¹ / ₄
	≥18	0	0	6 ¹ / ₄
GJD Series, Siemens	≥6 to <10	0	3 ¹ / ₂	6 ¹ / ₄
	≥10 to <18	0	0	6 ¹ / ₄
	≥18	0	0	6 ¹ / ₄

Actuator Mounting

Actuators may be installed at the factory, shipped loose with the necessary linkage and brackets for mounting, or field supplied. For more detail information on actuator mounting, click on link below or scan QR code.



ACTUATOR MOUNTING

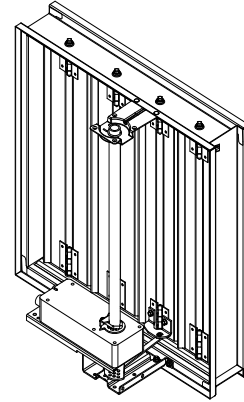

Non-jackshaft external right

Clearance Requirements

This drawing depicts the worst case clearance requirements for an actuator with a jackshaft.

Internal mount only Actuator model	A	B	C
All except - EFB & EFCX Series	7 ¾ in (197 mm)	3 ¾ in (95 mm)	5 ⅝ in (136.5 mm)
EFB & EFCX Series	8 ½ in (216 mm)	6 in (152mm)	8 ½ in (216 mm)

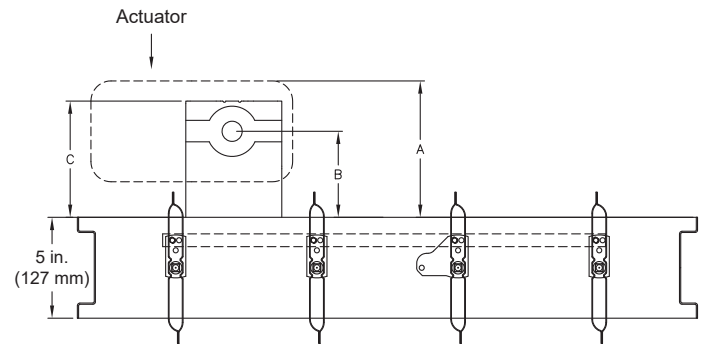

Multi-Section Dampers

Dampers larger than the maximum single section size, will be made up of a multiple of equal size sections. Multiple section dampers can be jackshafted together so that all sections operate together as shown below.

NOTE: Dampers larger than 74 in. x 60 in. (1880mm x 1524mm) are not intended to be structurally self supporting. Refer to IOM document 463384 for structural support requirements on multi-section assemblies.

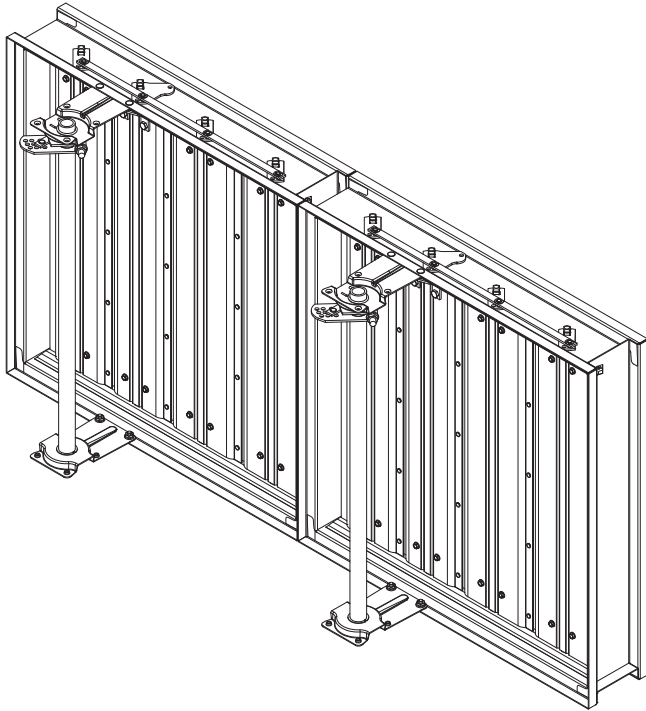

2 section example shows single jackshaft driving multiple sections

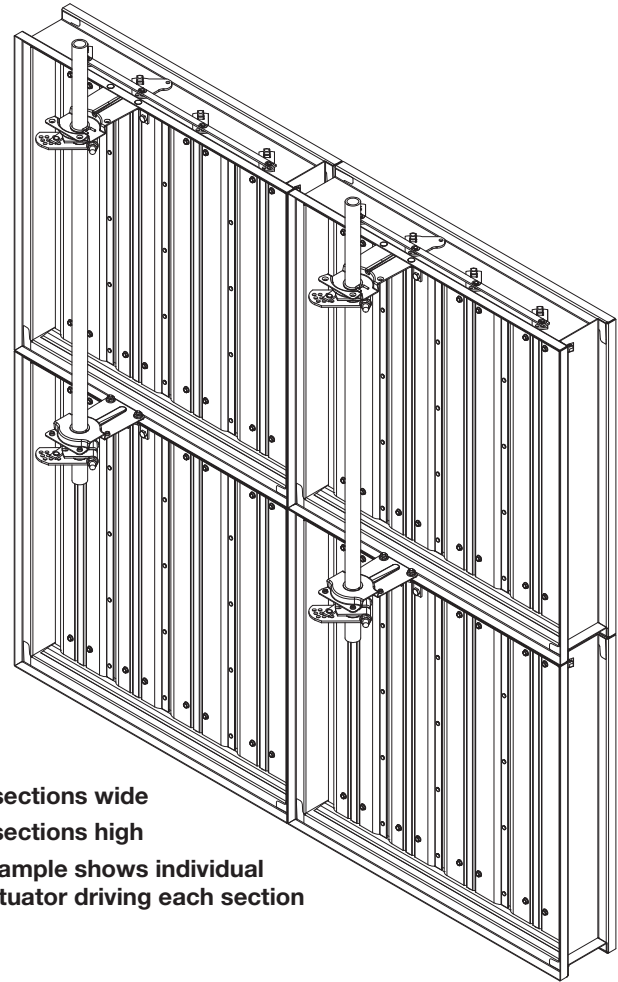

2 sections wide
2 sections high
example shows individual actuator driving each section