

## Installation, Operation and Maintenance Manual

Please read and save these instructions for future reference. Read carefully before attempting to assemble, install, operate or maintain the product described. Protect yourself and others by observing all safety information. Failure to comply with these instructions will result in voiding of the product warranty and may result in personal injury and/or property damage.

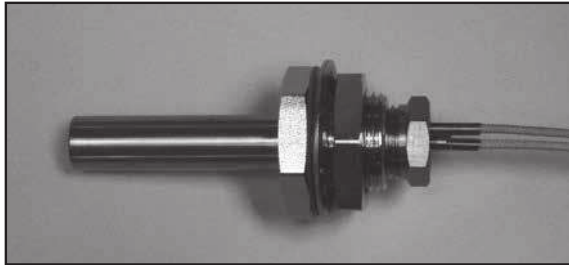

### Product Specification

#### Temperature Interlock

International Mechanical Code (IMC) compliant electrical package.

Provide Greenheck Fan Corporation temperature interlock electrical package as shown on plans and in accordance with the following specification:

The temperature interlock(s) consists of a time delay relay, adjustable thermostat, junction box, fire proof/leak proof threaded fitting (Evergreen Quik-Seal® and/or Evergreen Compression Seal), and shall be a self-contained unit or as part of another pre-engineered electrical control package.

The temperature interlock package shall close a time delay relay powering the fans when the set temperature is reached at the thermostat. The interlock shall hold the circuit closed upon fan switch being turned off until the temperature at the sensor decreases below the set point at which point the timed relay will begin a countdown. Once the countdown has expired and as long as the temperature has remained below the set point, the fans shall shut down.

The temperature interlock package shall be constructed by Greenheck Fan Corporation and operate in accordance with International Mechanical Code.

Due to continuous research, Greenheck Fan Corporation reserves the right to change specifications without notice.

### General Safety Information

Only qualified personal should install this product. Personnel should have a clear understanding of these instructions and should be aware of general safety precautions. Improper installation can result in electric shock and other potential hazards.

1. Follow all local electrical and safety codes, as well as the National Electrical Code (NEC) and latest edition of the National Fire Protection Agency Standard for Ventilation Control and Fire Protection of Commercial Cooking Operations (NFPA 96). Follow the Canadian Electrical Code (CEC) and ULC-S650 if installing this product in Canada.
2. Do not allow the electrical components of this product to come in contact with oil, grease, hot surfaces, water, or chemicals.
3. Verify the site can supply the necessary power for each fan and for the control panel.

#### WARNING

Electrical shock hazard. Can cause equipment damage, personal injury or death. Service must only be performed by personal that are knowledgeable in the operation of the equipment being controlled.

#### CAUTION

Always disconnect power before working on or near the product. Lock and tag the disconnect switch or breaker to prevent accidental power up.

#### CAUTION

It is the responsibility of the installer to make sure both electrical and gas appliances shut down in the event of a fire or in the event of a power loss to the building when this sequence is required by the authority having jurisdiction.

## Table of Contents

Product Specification . . . . .	1
General Safety Information . . . . .	1
General Description . . . . .	2
Receiving and Handling . . . . .	3
Installation	
Control Box Mounting . . . . .	3
Thermostat(s) - Hood Mounting . . . . .	3-4
Thermostat(s) - Duct Collar Mounting . . . . .	4
Electrical Connections	
Fan Starters Provided by Others . . . . .	5
All Exhaust/Supply Fan Starters Provided in Make-Up Air Unit (MUA) . . . . .	6
Thermostat Connections . . . . .	6
Calibration . . . . .	7
Control Circuit Diagram . . . . .	8
Testing . . . . .	9
Operation . . . . .	9
Troubleshooting . . . . .	10
Maintenance . . . . .	10
Frequently Asked Questions . . . . .	11
Replacement Parts . . . . .	11
Codes and Standards Compliance . . . . .	11
Our Commitment . . . . .	12

## General Description

### Description

The temperature interlock is designed to automatically start kitchen hood exhaust fans and keep them running while heat is being generated from the cooking appliances. Hood systems should always be manually started before equipment is turned on. If the operator fails to turn the fans on, the interlock will turn the fans on once enough heat is detected. The package consists of a time delay relay, adjustable thermostat, junction box, and a UL Listed, liquid-tight fitting. The relay can be contained in a stand alone box or can be added to a pre-engineered fan control center.

### Purpose

To meet IMC, an interlock between exhaust fans and cooking equipment must be present for all Type I hood systems. This product will utilize a thermostat in the exhaust duct collar or in the capture area of the hood to detect heat generated from cooking operations and automatically activate the exhaust fans if not already turned on.

### Product Application

The temperature interlock can be used with Type I and Type II hoods. It is not to be used in conjunction with exhaust fire dampers. Greenheck recommends using one interlock per hood system (activates all fans linked to systems simultaneously).

### Performance Goals

To meet IMC, the fans need to activate not more than 15 minutes after the first appliance served by that hood has been turned on. Ambient kitchen temperatures are not the same in all commercial kitchens. Therefore, set point adjustments may be necessary on the thermostat to make sure the system meets this 15 minute requirement.



## Receiving and Unpacking

### Receiving

Upon receiving the product, check to make sure all items are accounted for by referencing the bill of lading or packing list to ensure all items were received. Notify the carrier if any damage is noticed. The carrier will make notification on the delivery receipt acknowledging any damage to the product. All damage should be noted on all of the copies of the bill of lading which is countersigned by the delivering carrier. If damaged upon arrival, file a claim with the carrier. Any physical damage to the unit after acceptance is not the responsibility of the manufacturer.

### Unpacking

Verify that all required parts and the correct quantity of each item have been received. If any items are missing, report shortages to your local representative to arrange for obtaining missing parts.

### Storage

If a temperature interlock must be stored prior to installation, it must be protected from dirt and moisture. Indoor storage is highly recommended.

#### NOTE

Improper storage which results in damage to the unit will void the warranty.

### Handling

Make sure the equipment does not suffer any heavy vibration or knocks.

## Installation

### Control Box Mounting

#### NOTE

Control box may be factory mounted. If so, continue to the next section.

Locate an area with enough space to mount the control box and fasten to the wall. Avoid installing the control box in environments with high magnetic and/or radio frequency interference.

### Thermostat(s) - Hood Mounting

#### NOTE

Thermostat sensor(s) may be factory installed. If so, continue to the next section.

1. Locate the flat area(s) at the top interior of the hood in front of the filters, towards the front of the hood.

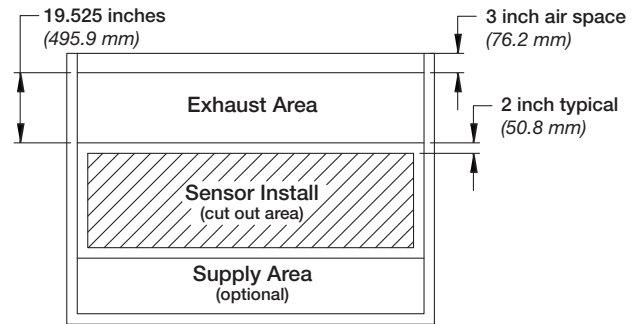

Hood Plan View

2. Find a suitable location for the sensor in the flat space that will not interfere with the fire suppression nozzles and that is not within 12 inches (304.8 mm) of any light fixtures. Cut a 1½ to 1¼ inch (28.6 to 31.8 mm) diameter hole in the flat spot of the capture tank.
- 
- The diagram shows a cross-section of the hood surface with a hole. The hole is labeled '1½ to 1¼ inch (28.6 to 31.8 mm) diameter hole' and the surface is labeled 'Hood Surface'.
  3. Place the J-box plate inside the octagon extension ring and place over the hole.
  4. Disassemble the compression seal and place through hole and J-box plate as shown. Tighten the nut inside the octagon extension ring.

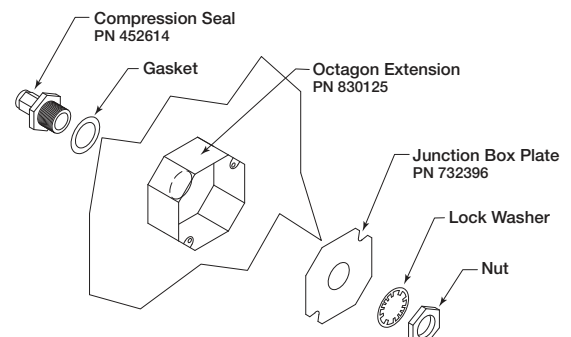

Exploded View (Components)

## Installation - continued

- Place the thermostat through compression seal and tighten the compression fitting to 35 ft.-lbs. (47.5 Nm).
- Wire the thermostat. Refer to Electrical Connections section for instructions on wiring the thermostat.
- Place octagon cover onto J-box and fasten it.

### Thermostat(s) – Duct Collar Mounting

- Locate the exhaust duct on top of the hood. Find a spot to mount the thermostat where it will not interfere with fire suppression nozzles or other items installed in the ducts. If an exhaust fire damper is present in the hood exhaust collar, it must be removed prior to temperature sensor installation. A  $1\frac{1}{8}$  to  $1\frac{1}{4}$  inch (28.6 to 31.8 mm) diameter hole must be cut into the duct 2 inches (50.8 mm) above the hood top.

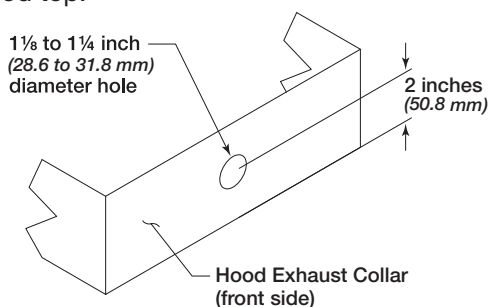

- Place the J-box plate inside the octagon extension ring and place over the hole in the exhaust collar.
- Disassemble the Quik-Seal fitting and place through hole in duct collar and J-box plate as shown. Tighten the nut inside the octagon extension ring.

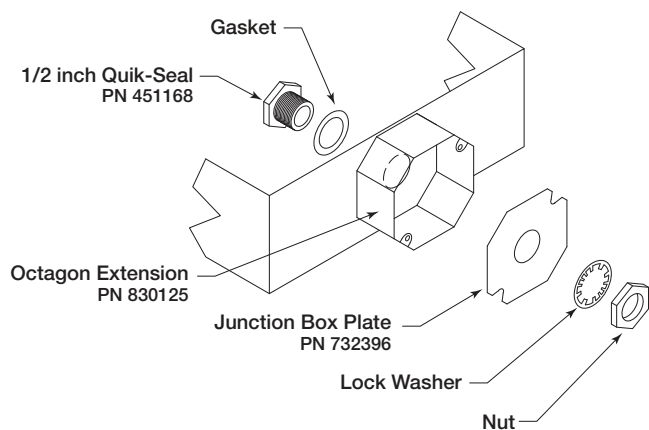

#### Exploded View (Components)

- Thread the thermostat into the Quik-Seal fitting until secure.
- Wire the thermostat. Refer to Electrical Connections section for instructions on wiring the thermostat.
- Place octagon cover onto J-box and fasten it.

# Electrical Connections

## NOTE

All wiring of electrical equipment must be done to meet NEC and local codes.

## NOTE

All field wire must be high temperature rated. All 115 VAC field wiring (or higher) must be routed through hard or flex conduit. All low voltage field wiring should be plenum rated if not routed through conduit. Field wiring should not come in contact with the surface of the hood. To reduce the likelihood of electromagnetic disturbance, avoid routing high and low voltage cables in the same cable conduit.

## NOTE

Temperature interlock may be integrated into the kitchen fan control center (KFCC). The electrical information below pertains to stand-alone temperature interlock packages only. For more details on wiring the KFCC, please refer to the proper IOM which can be found on the Greenheck website, [www.greenheck.com](http://www.greenheck.com).

### All Fan Starters Provided by Others

1. Wire 115 VAC power from non-shunted breaker to terminal blocks H1 (hot) and N1 (neutral) in temperature interlock panel.
2. Wire fan switch (either provided in field, shipped loose for remote install, or provided on hood/hood utility cabinet) to terminal blocks S1H and S1 in temperature interlock panel.
3. Wire AC voltage needed to activate fan starters (115 or 24 VAC) to terminal block CP1 (hot).
4. Wire one side of all exhaust fan starter coils to terminal block CP2.
5. If Type I hood, wire common (C) of dedicated fire system microswitch to terminal block CP2.
6. If Type I hood, wire normally open (NO) to fire system microswitch mentioned in item 5 above to terminal block CP1.
7. If Type I hood, wire normally closed (NC) of fire system microswitch mentioned in item 5 above to one side of all supply fan starter coils. If Type 2 hood, wire supply fan starter coils directly to terminal block CP2.
8. Wire the other side of all exhaust fan and supply fan starter coils back to neutral.
9. Wire thermostats in parallel and connect between terminal blocks T1-A and T1-B (see Thermostat(s) Sensors section for details).

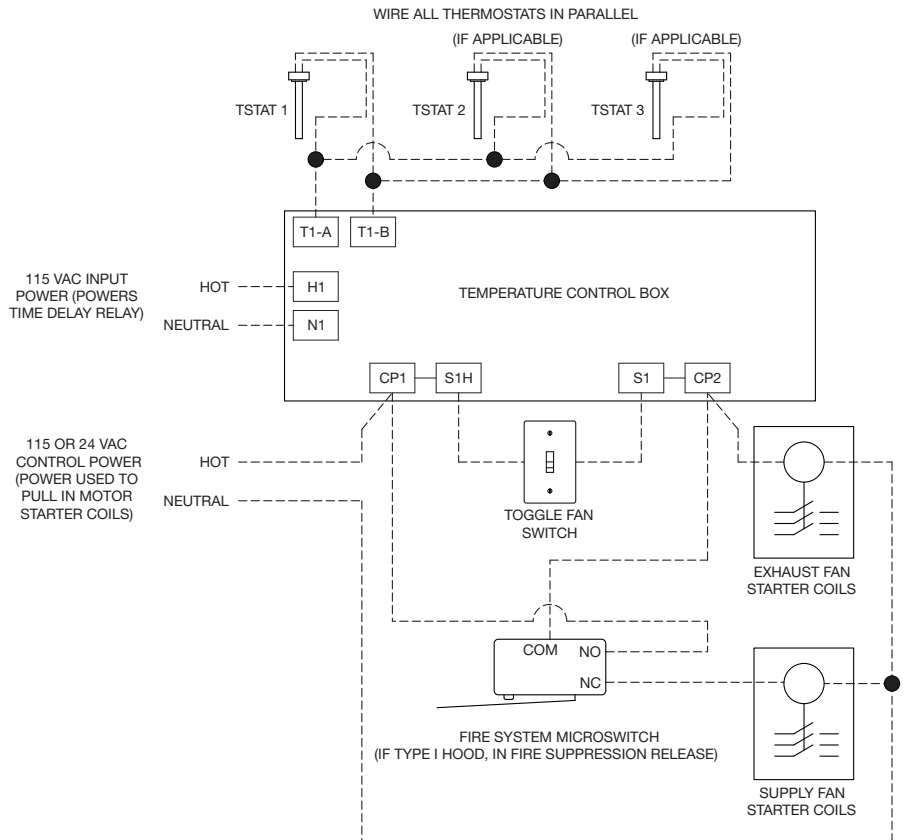

## NOTE

CP1 and CP2 are dry contacts from the factory. The field needs to wire AC power they want to use to activate their fan starters to terminal block CP1. All exhaust fan starters need to be wired between CP2 and a neutral. **Contacts used to make this connection on the time delay relay are rated up to 125 VAC and 10 amps.** Make sure the control circuit does not exceed these ratings. If exceeded, this can damage the contacts on the relay which will require replacement.

## Electrical Connections - continued

### All Exhaust/Supply Fan Starters Provided in Make-Up Air Unit (MUA)

1. Wire 115 VAC power from non-shunted breaker to terminal blocks H1 (hot) and N1 (neutral) in temperature interlock panel.
2. Wire fan switch (either provided in field, shipped loose for remote install, or provided on hood/hood utility cabinet) to terminal blocks S1H and S1 in temperature interlock panel.
3. If Type I hood, wire common (C) of dedicated fire system microswitch to terminal block CP2.
4. If Type I hood, wire normally open (NO) of fire system microswitch mentioned in item 3 above to terminal block CP1.
5. Run three (3) low voltage wires (18 gauge) from MUA unit control center down to temperature interlock panel.
  - a. Terminal block R in MUA connects to terminal block CP1 in temperature interlock panel.
  - b. Terminal block H in MUA connects to terminal block CP2 in temperature interlock panel.
  - c. If Type I hood, wire terminal block G in MUA to normally closed (NC) of fire microswitch mentioned in 3 above. If Type II hood, wire terminal block G in MUA to terminal block CP2 in temperature interlock panel.
6. Wire the thermostats in parallel and connect between terminal blocks T1-A and T1-B (see Thermostat(s) Sensors section for details).

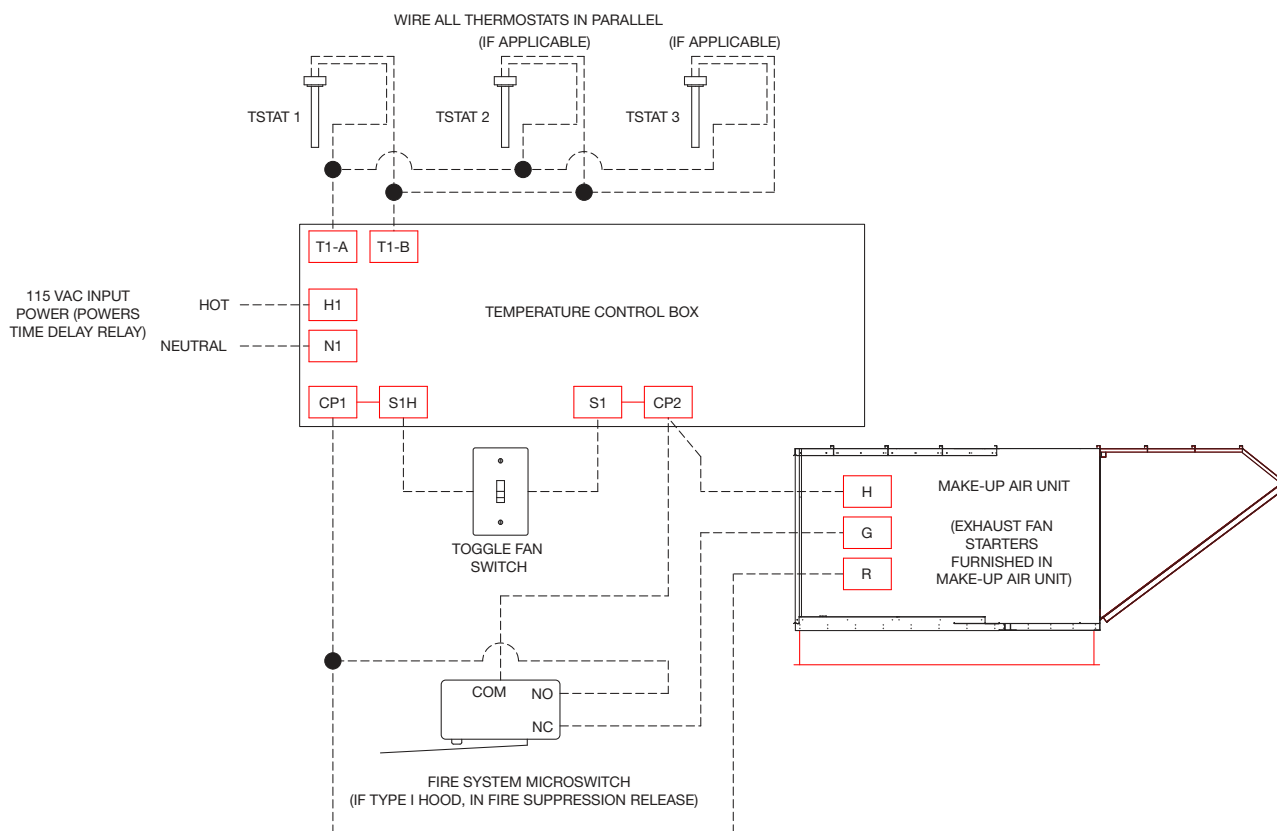

### Thermostat(s)

Unless already done by the factory, wire all thermostats in a parallel back to terminal blocks T1-A and T1-B in temperature interlock panel using 14 gauge 90°C minimum conductors.

#### CAUTION

Do not connect temperature sensor in series with fan power. Depending on motor amperage, this can cause damage to the thermostat and potentially the fan motor.

## Calibration

---

Thermostat is preset by factory to 95°F (35°C) and has a slow make and break contact. It will make contact on a temperature rise and break contact on temperature fall. The temperature set point may have to be adjusted slightly depending of both ambient and cooking conditions. The adjustment knob is located on the back of the thermostat. Use a small blade screwdriver to make the adjustments.

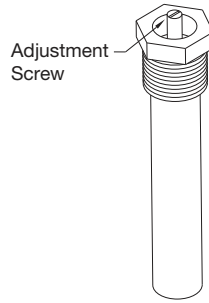

1. Turn counterclockwise to increase the temperature set point, turn clockwise to decrease the temperature set point.
2. Quarter revolution in either direction corresponds to a 22.5°F (-5.3°C) adjustment. Be sure to make small adjustments, about 1/16 of a turn ( $\approx 6^\circ\text{F}$ ) or less at one time.
3. Do not exceed more than one-half revolution in either direction.
4. Check system operation before making additional adjustments.

# Control Circuit Diagram (Stand-Alone Package)

This is an example of a generic wiring diagram for standard control. It provides temperature interlock function for two exhaust fans and one supply fan. (All starters provided by others, external to this control box).

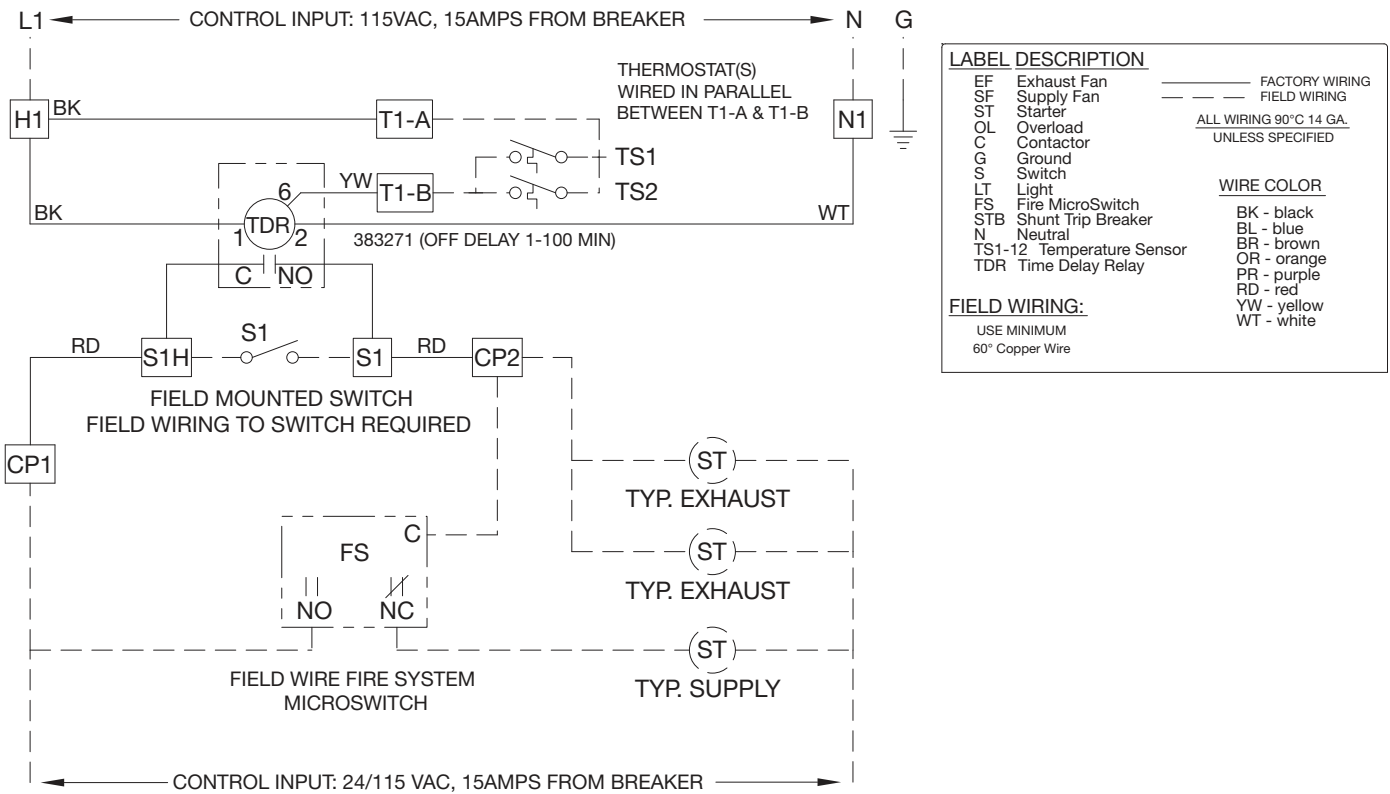



## Testing

1. Turn fan switch on, then off to ensure proper fan operation before cooking equipment is started. Once this is verified, testing can proceed.
2. For testing only, locate the time delay relay. Turn the time adjustment knob counterclockwise to the first mark in order to expedite the testing process. Make a note as to where the time relay was originally set.
3. Heat up cooking equipment with fans off. Once the temperature reaches the set point of the thermostat the fans will start, preferably within 5 to 10 minutes. If the fans take more than 15 minutes to start, decrease the temperature set point by turning the adjustment screw 1/16 turn clockwise. Do not apply direct flame to the thermostat
4. If an adjustment was made in Step 3, repeat now.
5. After verification of fan start-up, shut down cooking equipment. The fan switch should still be in the off position. Once cooking equipment has cooled, the thermostat will open triggering the timer function in the time delay relay to begin. Once time has expired, the fans will shut down. Thermostat operation can be verified by checking voltage (115 VAC) between terminal blocks T1-B and N1 in the control panel.
6. Once proper operation has been verified, set the dial on the timed relay to its original setting (approximately 20 minute delay).

### CAUTION

The thermostats should never be exposed to direct flame. This can cause permanent damage to the thermostat.

### NOTE

During testing, if fans do not start automatically in the first 15 minutes of cooking equipment activation, manually start fans to avoid accidental fire system dump due to heat build-up.

## Operation

1. Turn fans on and off using the fan switch. It is normal for the fans to remain running after the switch is turned off. The exhaust thermostat will open after heat is no longer present under the hood which will activate the timed relay to begin its countdown. Once time has expired, fans will shut down. The timed relay is adjustable from 1-100 minutes. The recommended time delay setting is approximately 20 minutes.
2. In the event that the cooking equipment is started without turning the fans on manually, the fans will turn on automatically and remain running with the presence of heat under the hood. The exhaust thermostat will open after heat is no longer present under the hood which will activate the timed relay to begin its countdown. Once time has expired, fans will shut down.

## Troubleshooting

---

### ***Fans do not turn on automatically upon cooking equipment activation.***

- Check wiring to control panel. Thermostats must be wired in parallel.
- Temperature set point too high, decrease set point
- No power to fans, check breakers/starters/relays

### ***Fans do not shut off.***

- Fan switch must be in the off position
- Cooking equipment hot, wait for it to cool
- Temperature set point too low, increase set point
- Check control circuit (fan starter) wiring
- Time delay too great, turn down timed relay

### ***Fans do not turn on quick enough.***

- Decrease temperature set point

## Maintenance

---

### **Daily**

Clean thermostat with cloth and degreaser. Keep clean for best performance. (Can clean weekly depending upon grease accumulation).

### **Weekly**

Dependant on grease production and grease filter type, clean thermostat.

### **Seasonal**

May have to change temperature setting on back of thermostat if ambient kitchen temperatures fluctuate between summer and winter seasons.

### **Whom to call**

Contact your local Greenheck representative.

### **What to have ready for the call**

Sales order, serial number and description of product.

Sales Order Number \_\_\_\_\_

Serial Number \_\_\_\_\_

## Frequently Asked Questions

**What temperature is the thermostat set from the factory?**

95° Fahrenheit.

**Will the temperature interlock automatically start/stop the fans?**

When connected properly to fan starters the temperature interlock will automatically control the fans without input from the user. However, it is intended to be used as a back-up to manual control.

**May I connect the power going to my fan directly through the control box?**

No, the control box should only use control voltage only (24-115 VAC), and a separate 115 VAC power source is required to run the temperature interlock controls. Greenheck recommends the use of starters sized for each fan.

**What is the purpose of the timed relay in the control box?**

The timed relay is used to delay the shut down of the fans to prevent fan on/off cycling while the temperature in the exhaust duct can reach steady state. Without the delay, cycling could occur both on startup or shutdown of cooking equipment. The delay is typically set at 20 minutes.

**Can I use one control box for multiple hood systems?**

This can be done, however, it is not recommended. Any one of the thermostats would turn on all hoods running on that control box. It is better to have one hood/fan per control box, plus a significant energy savings can be obtained if one or more of the hoods is not in operation.

**Can I still turn my fan on and off?**

Yes, the temperature interlock is designed to be operated with a typical on/off switch. The fan may not turn off immediately after turning the fan switch off, it will sense when the cooking operations have cooled and then turn off.

## Replacement Parts

Part Number	Description
383923	Thermostat, Vulcan 1C2B9 5/8-inch Type C
451168	Evergreen Quik-Seal, 1/2-inch #171 (1-1/8 inch hole size)
830125	Extension, Octagon (drilled) SC55151-1/2 (380928)
380926	Cover, Octagon Box SC#54-C-1RACO 722
732396	J-Box Plate
384905	Terminal Block, Single Pole, DIN-RAIL MT, ABB ZS6
384908	Jumper, DIN-RAIL Terminal Block 2 Pole ABB JB6-2
383271	Time Delay Relay SSAC #KRDB424 SPST 1-100 min.
452614	Evergreen Compression Seal, 5/8-inch, #302

## Codes and Standards Compliance

- UL 710
- National Fire Protection Association (NFPA 96)
- International Mechanical Code (IMC)

## Our Commitment

---

*As a result of our commitment to continuous improvement, Greenheck reserves the right to change specifications without notice.*

Product warranties can be found online at [Greenheck.com](http://Greenheck.com), either on the specific product page or in the literature section of the website at [Greenheck.com/Resources/Library/Literature](http://Greenheck.com/Resources/Library/Literature).

AMCA Publication 410-96, Safety Practices for Users and Installers of Industrial and Commercial Fans, provides additional safety information. This publication can be obtained from AMCA International, Inc. at [www.amca.org](http://www.amca.org).

