

## Installation, Operation and Maintenance Manual

Please read and save these instructions for future reference. Read carefully before attempting to assemble, install, operate or maintain the product described. Protect yourself and others by observing all safety information. Failure to comply with instructions could result in personal injury and/or property damage!

### Energy Recovery Filter System



### General Description

#### Description and Purpose

The energy recovery filter system is an arrangement of high efficiency grease filters with heat recovery coils to be mounted in a commercial kitchen hood and piped back to an existing water heater. While the smoke and effluent generated off the commercial cooking appliances will naturally be filtered, the heat generated by the cooking process will be used to preheat water being supplied to the water heater, thus reducing operating expenses and the need for larger and more expensive hot water heaters.

#### WARNING

Electrical shock hazard. Product contains electrically activated components. This can cause equipment damage, personal injury, or death. Service must only be performed by personnel that are knowledgeable in the operation of the equipment being controlled. Read the installation, operation, and maintenance instructions thoroughly before installing or servicing this equipment.

#### DANGER

Always disconnect power before working on or near the control panel provided. Lock and tag the disconnect switch or breaker to prevent accidental power up.

#### CAUTION

All field installation of electrical equipment must be done to meet all NEC and electrical codes.

## Table of Contents

Receiving, Unpacking, Handling, Storage . . . . .	2
Installation	
Components and Installing Control Cabinet . . . . .	2
System Installation . . . . .	3
Plumbing and Electrical Requirements . . . . .	4
Control Cabinet Layout . . . . .	4
Operation . . . . .	5
Maintenance . . . . .	5
Balancing and Testing Methods . . . . .	6
Troubleshooting . . . . .	7
Replacement Parts . . . . .	7
Codes and Standards . . . . .	7
Our Commitment . . . . .	8

**Receiving** - Upon receiving the product, check to make sure all items are accounted for by referencing the bill of lading to ensure all items were received. Inspect each crate for shipping damage before accepting delivery. Notify the carrier if any damage is noticed. The carrier will make notification on the delivery receipt acknowledging any damage to the product. All damage should be noted on all of the copies of the bill of lading which is countersigned by the delivering carrier. A Carrier Inspection Report must be filled out by the carrier upon arrival and reported to the Traffic Department. If damaged upon arrival, file a claim with the carrier. Any physical damage to the unit after acceptance is not the responsibility of the manufacturer.

**Unpacking** - Verify that all of the required parts and the correct quantity of each item have been received. If any items are missing, report shortages to your local representative to arrange for obtaining missing parts. Sometimes it is not possible that all items for the unit be shipped together due to availability of transportation and truck space. Confirmation of shipment(s) must be limited only to items on the bill of lading.

**Handling** - Make sure the equipment does not suffer any heavy vibration or knocks. Handle in such a manner as to keep from scratching or chipping any coating. Damaged finish may reduce the ability of unit to resist corrosion.

**Storage** - Products are protected against damage during shipment. If the product must be stored prior to installation, it must be protected from dirt and moisture. Indoor storage is highly recommended. For outdoor storage, cover the control package with a tarp to keep it clean, dry. The user assumes responsibility of the equipment and accessories while in storage. The manufacturer will not be responsible for damage during storage. These suggestions are provided solely as a convenience to the user.

### NOTE

Improper storage which results in damage to the unit will void the warranty.

## Installation

### NOTE

All installation must follow local plumbing and electrical codes.

### Components

Components included with the energy recovery filtration system.

Quantity	Description
Varies	Two size options: <ul style="list-style-type: none"> <li>• 20 inch high x 20 inch wide (50.8 x 50.8 cm) or</li> <li>• 16 inch high x 20 inch wide (40.64 x 50.8 cm)</li> </ul> Special energy recovery filters with quick couplers and hoses attached
2	3/8 inch (0.95 cm) UL Listed hood penetration seal
1	18 inch (45.72 cm) stainless steel hose
1	24 inch (60.96 cm) stainless steel hose
1	24 inch high x 36 inch wide x 14 inch deep (60.96 x 91.44 x 35.56 cm) control cabinet
1	Male disconnect
1	Female disconnect
1	Filter spacer

### Installing Control Cabinet

The cabinet should be mounted to a secure surface through the holes around the back perimeter of the cabinet. Use

at least six (6) mounting holes evenly spaced around the back perimeter of the cabinet. If the pre-drilled holes do not work, drill additional holes around the perimeter for mounting. The cabinet will weigh approximately 85 pounds (38.56 kg).

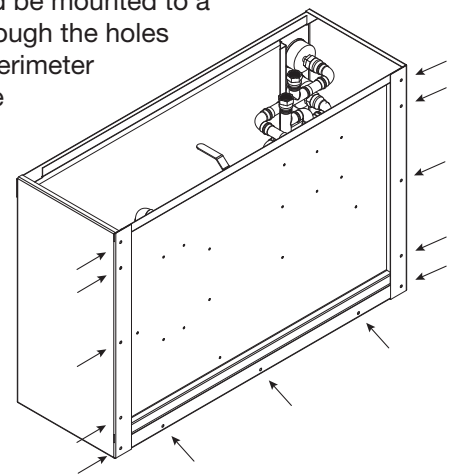

### NOTE

It is the responsibility of the installer to ensure studs or other structural members should be the point of fastening when attaching this cabinet to a wall.

# System Installation

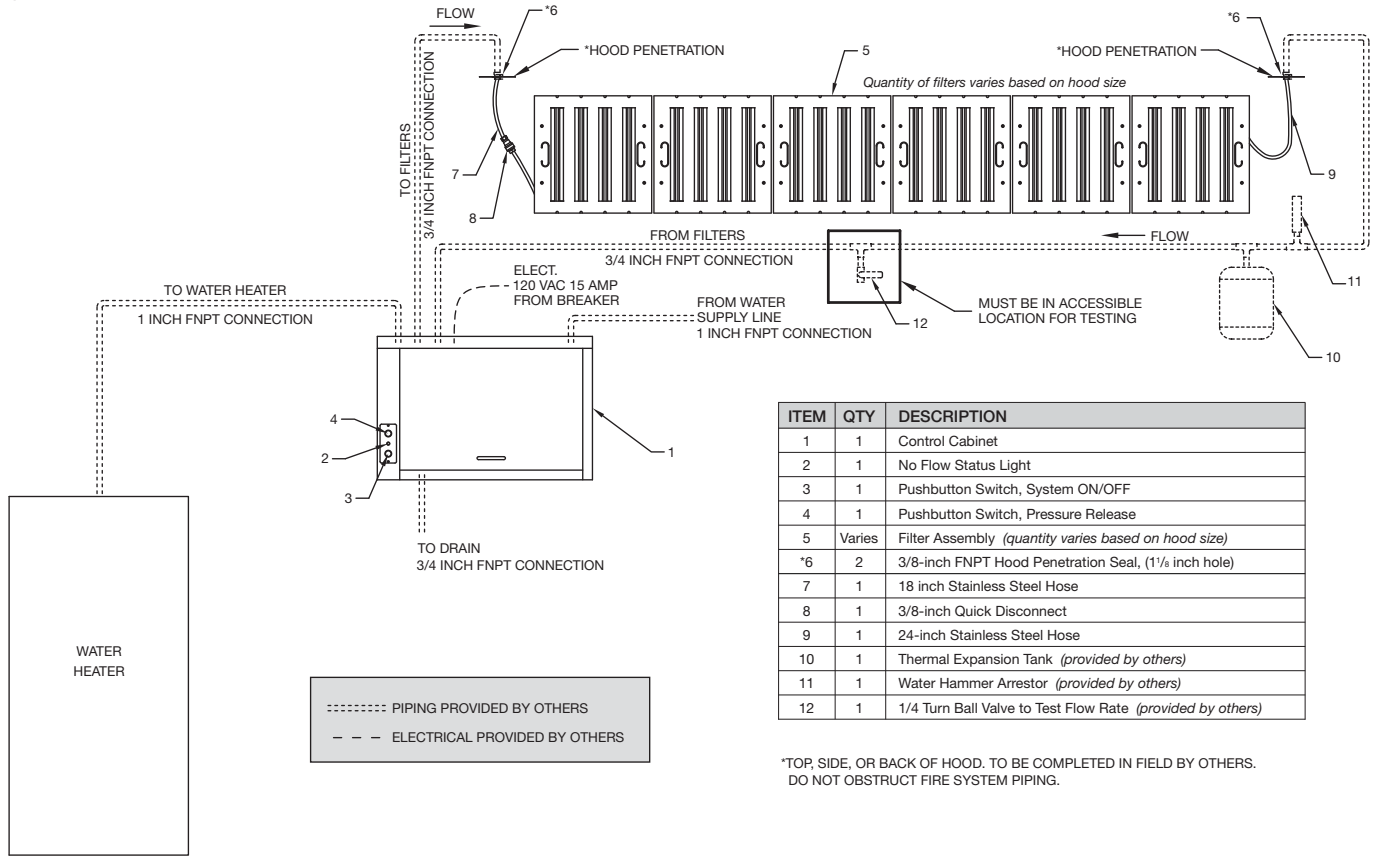

- Remove the existing filter(s) from commercial kitchen hood for retrofit or from the shipping container for a new installation.
- Drill two 1 1/8-inch holes in the hood top, side or back above the filter rack, one close to the left and one close to the right side of the hood.

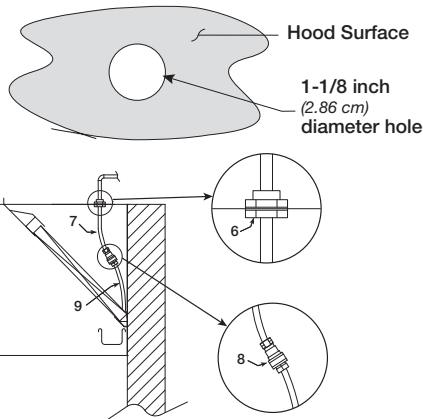

- Install a hood penetration seal (item 6) in the hood top above the filter rack. To do this, disassemble the compression seal and insert the seal into the hole from the inside of the hood making sure the gasket is placed on the fitting before inserting it into the hole. Install the lock washer and nut and tighten securely as shown.

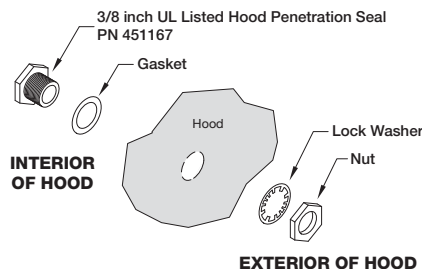

- Attach the 18 inch stainless steel hose (item 7) to the left-most hood penetration seal, and the 24 inch stainless steel hose (item 9) to the right-most hood penetration seal.
- Attach the extra female coupler to the 18 inch hose (item 7) on left end of the hood, and the male coupler to the 24 inch hose (item 9) on the right end of the hood.
- Install new filters in hood from left to right. Hook up the quick-connect couplers between the filter assemblies.
- If applicable, install adjustable filter spacers to fill in the gap(s) on the hood ends.
- Install all other plumbing, as shown on this drawing. Please refer to plumbing requirements section on page 4 for more information.
- Make all of the electrical connections. Please refer to electrical requirements section on page 4 for more information.

## Plumbing Requirements

1. Connect the main water supply connection to the 1-inch FNPT connection labeled "FROM WATER SUPPLY".

### NOTE

The water supply line must be pressurized to 40 PSI minimum.

2. Provide the piping from the water heater to the 1-inch FNPT connection labeled "TO WATER HEATER".
3. Provide the piping from the left-most hood penetration seal on hood to the 3/4-inch FNPT connection labeled "TO FILTERS".
4. Provide piping from the right-most hood penetration seal on the hood to the 3/4-inch FNPT connection labeled "FROM FILTERS". In line within this pipe run, provide a water hammer arrestor (provided by others), a thermal expansion tank (provided by others), and a 3/4-inch turn ball valve to test the flow rate (provided by others). This ball valve needs to be in an accessible location for testing.
5. Provide piping to an external drain from the 3/4-inch FNPT connection labeled "TO DRAIN".

## Electrical Requirements

Located in a NEMA-3R box in the center of the control cabinet is the electrical connection cabinet. Both the pump and pressure release solenoid valve will be wired to the electrical connections cabinet from the factory.

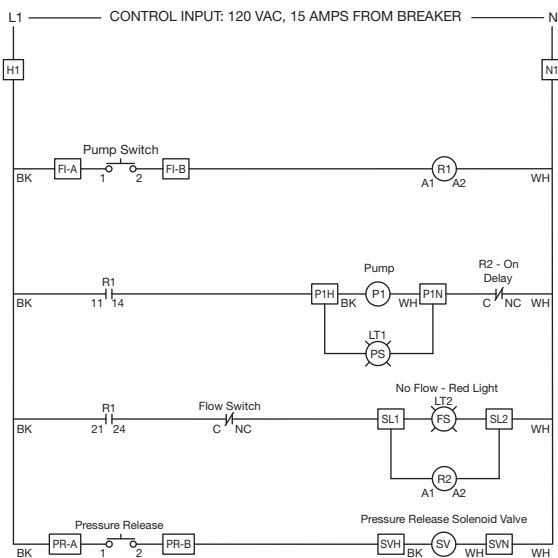

Connect 120 VAC power from a 15 amp breaker to terminals H1 and N1.

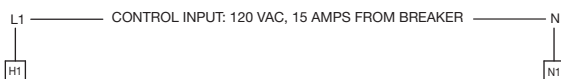

## Control Cabinet Layout

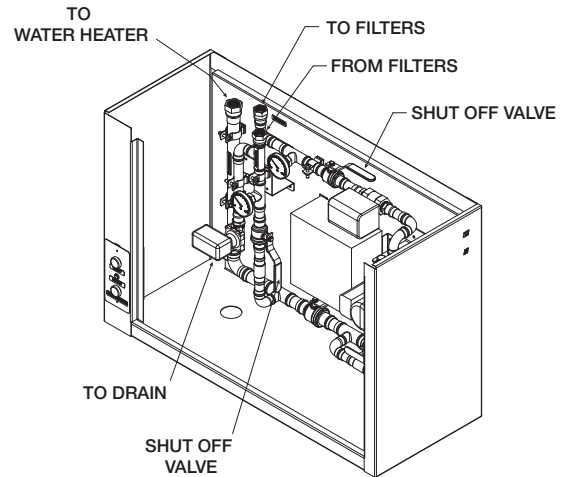
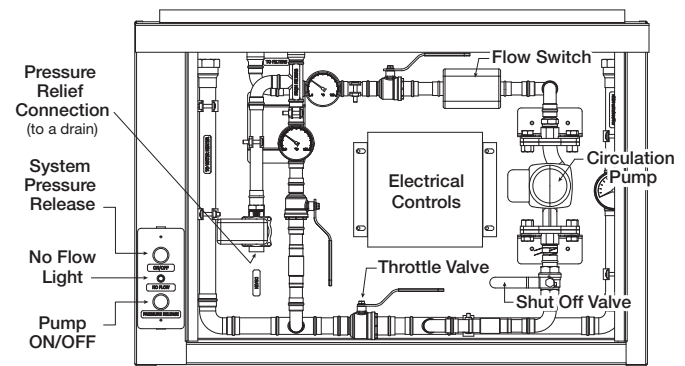

### WARNING

Leave the pump running during cold weather conditions to prevent freezing during cold temperatures.

## Operation

### Start-Up Procedure

1. Turn on the fan for the kitchen hood.
2. Turn on the cooking equipment.
3. When the equipment reaches operating temperature, push the green ON/OFF button on the control cabinet to turn the system on.
4. Adjust the “Throttle Valve” to maximize overall energy savings.
  - Start with the valve half open.
  - Monitor the “Inlet” temperature gauge on control cabinet and adjust the “Throttle Valve” to maximize the “Outlet” temperature.
  - Do not completely close “Throttle Valve”, make sure valve is at least one-quarter open.
  - To maximize savings, the “Throttle Valve” must be set during peak cooking conditions.
5. Turn the cooking equipment off.
6. Push the green ON/OFF button on the control cabinet to turn the system off.
7. Turn the fan off for the kitchen hood.

### NOTE

Do not completely close the “Throttle Valve” when the system is operational.

### Sequence of Operation

1. During cooking operations, turn on the fan for the kitchen hood.
2. Push the green ON/OFF button on the control cabinet to turn on the energy recovery filter system.  
**NOTE:** If flow is not detected, the red light will illuminate and the circulation pump will shut down. If this occurs, stop the system and verify filters are properly connected and all valves are open.
3. After cooking operations, push the green ON/OFF button on the control cabinet to turn off the energy recovery filter system.
4. Turn off the fan for kitchen hood.

## Maintenance

### Cleaning filters

Filters should be cleaned a minimum of once a week depending on the cooking equipment, cooking frequency, food type and quantity. When servicing or cleaning the filters, turn the pump power off (green button on control cabinet should not be lit). Close the ball valve in the cabinet that supplies the water to the filters. Then press the ‘Pressure Release’ button on the control cabinet for about 5-10 seconds.

### WARNING

Make sure the “Pressure Release” button is pressed before disconnecting anything. If system is not purged properly, water spillage can occur, which can cause hot water burns.

### NOTE

Do not wash coil with a high pressure washer, as it will damage the fins.

Do not take filter apart and clean it unless you are a trained service technician. This is to prevent the coated aluminum fins from being damaged.

When washing assembled filters in a dishwasher, it is recommended to use Ecolab® Solid Metal Pro®

### When serviced by untrained personnel:

1. Remove filter spacer from the hood.
2. Disconnect the quick connect couplers between the filter assemblies.
3. Remove the filters from hood.
4. Place the filters, assembled, into a deep sink or dishwasher and wash thoroughly.
5. Place the filters back into hood.
6. Hookup the quick couplers between the filters and to the connections on the hood.
7. Insert the filter spacer.

### If normal cleaning techniques are not adequately cleaning the filters, then a trained service technician should be requested to service as follows:

1. Remove the filter spacer from the hood.
2. Disconnect the quick connect couplers between filter assemblies.
3. Remove the filters from hood.
4. Position the filter on its back, face up, and unscrew the four truss head machine screws from filter face.
5. Turn the filter over so it lies on its face.
6. Remove the filter back from assembly.
7. Remove the coil section from assembly.
8. Wash all three parts (front, back, and coil) in a sink with mild detergent.
9. After all the parts are clean, lay the filter front face down, and place the coil into the filter front. Make sure the hose connection is on the bottom of the filter.
10. Place the filter back over the top of the coil.
11. Turn the filter over so the face is now visible and replace the four machine screws.
12. Place the filter assembly back into the hood.
13. Hookup quick couplers between the filters and to the connections in the hood.
14. Insert filter spacer.

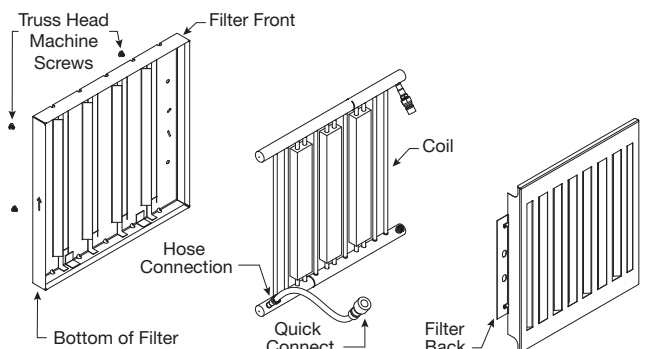

# Balancing and Testing Methods

## Shortridge Method

With all the filters in place, determine the total hood exhaust volume with a Shortridge meter as follows:

1. All of the cooking equipment should be on. If the hood has internal short circuit make-up air, it should be turned off.
2. Measure velocities
  - Set up the Shortridge meter.
  - For 20 in. (500 mm) wide filters, position the grid as shown in Fig. A and B. Average the two measurements.
  - Take velocity readings for each filter.
3. Calculate each filter's volumetric flow rate as follows:
 

Calculate each filter's average velocity by summing the velocity readings and dividing by the number of readings for each filter.

Multiply the average velocity by the conversion factor to obtain the volumetric flow rate for each filter.
4. Calculate the hood's total volumetric flow rate by summing the volumetric flow rate of each individual filter in the hood as calculated in Step 3.

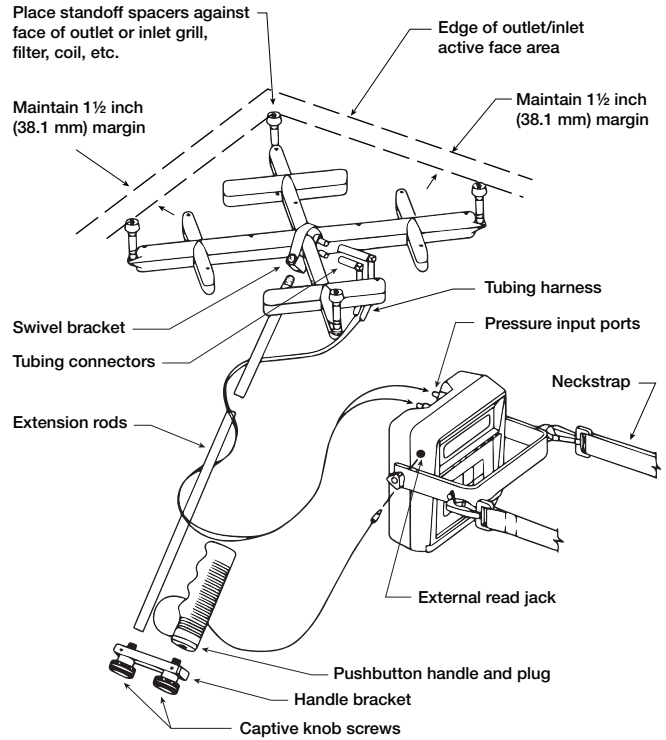

**NOTE**

For best accuracy, multiply the velocity of each filter by its conversion factor and sum the flow rates. Averaging the velocity measured for all filters may cause error.

Nominal Filter Size (H x L)		Imperial Conversion Factor	Metric Conversion Factor
Inches	Millimeters		
20 x 20	500 x 500	3.0	.279
16 x 20	400 x 500	2.0	.185

**Example: Measured velocities for a 20 x 20 filter = 185 and 189 ft/min.**

$$\text{Average Velocity} = \frac{\text{Sum of Velocity Readings}}{\text{Number of Readings}}$$

$$\text{(Imperial)} = \frac{185 + 189}{2} = \underline{187.0 \text{ ft/min.}}$$

$$\text{(Metric)} = \frac{3383 + 3456}{2} = \underline{3420 \text{ m/hr}}$$

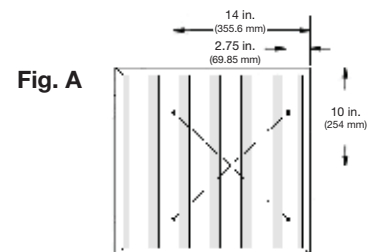

$$\text{Flow rate for one filter} = \text{Conversion Factor} \times \text{Average Velocity}$$

$$\text{(Imperial)} = 3.0 \times 187.0 \text{ ft/min.} = \underline{561.0 \text{ cfm}}$$

$$\text{(Metric)} = .279 \times 3420 \text{ m/hr} = \underline{954 \text{ m}^3\text{/hr}}$$

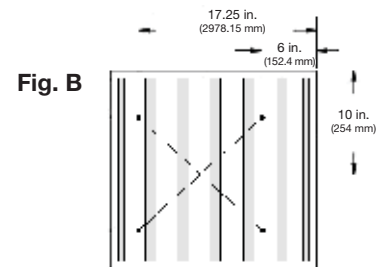

$$\text{Total hood flow rate} = (\text{Filter 1 Flow Rate}) + \dots + (\text{Filter x Flow Rate})$$

$$\text{(Imperial)} = 561.0 + 555.2 + 534.6 + 539.9 = \underline{2190.7 \text{ cfm}}$$

$$\text{(Metric)} = 954 + 944 + 909 + 918 = \underline{3725 \text{ m}^3\text{/hr}}$$

## Troubleshooting

### ***Pump does not run.***

- Confirm the fans are running and the pump switch has been pressed to activate the pump.
- Check voltage on terminals H1 and N1 in the electrical panel to confirm that there is 120 VAC.
- Check voltage on terminals P1H and P1N and confirm that there is 120 VAC.
- Inspect motor for disconnected wires.
- Motor may be faulty or failing, service motor.

### ***Hot water heater inlet temperature is not hot enough.***

- Confirm that the panel is running during cooking operations/fan operation.
- Confirm appliances are running.
- Close off the throttle valve to help force more water through the filters.

### **WARNING**

Do not close the throttle valve completely, as there may not be enough water supplied to the water heater.

### ***Pressure release button will not purge water to drain.***

- Confirm the ball valve that supplies water to the filters is closed.
- While holding the button, check the voltage between SVH and SVN to confirm 120 VAC.
- The pressure release solenoid valve may be faulty or failing, service solenoid valve.

### ***No flow light is on.***

- Confirm ball valves are open.
- Check quick connect fittings to ensure they are properly installed and connected to allow flow.
- Check for frozen or broken water lines.

## Replacement Parts

Part Number	Description
<b>Filter Part Numbers</b>	
475863	Core Heat Exchanger
476407	18 inch (45.72 cm) Stainless Steel Hose
476411	Relief Valve
476409	Female Coupler
476410	Male Coupler
<b>Cabinet Part Numbers</b>	
459010	Temperature/Pressure Gauge
381050	Solenoid Valve
381049	Coil for Solenoid Valve
476329	Pump
<b>System Parts</b> (shipped loose)	
476408	24 inch (60.96 cm) Stainless Steel Hose
451167	3/8 inch (0.95 cm) UL Listed Hood Penetration Seal
476409	Female Coupler
476410	Male Coupler

## Codes and Standards Compliance

- UL 1046
- NSF/ANSI Standard 2 – Food Equipment

## Our Commitment

---

*As a result of our commitment to continuous improvement, Greenheck reserves the right to change specifications without notice.*

Specific Greenheck product warranties are located on [greenheck.com](http://greenheck.com) within the product area tabs and in the Library under Warranties.

AMCA Publication 410-96, Safety Practices for Users and Installers of Industrial and Commercial Fans, provides additional safety information. This publication can be obtained from AMCA International, Inc. at [www.amca.org](http://www.amca.org).

