

## Installation, Operation and Maintenance Manual

Please read and save these instructions for future reference. Read carefully before attempting to assemble, install, operate or maintain the product described. Protect yourself and others by observing all safety information. Failure to comply with these instructions will result in voiding of the product warranty and may result in personal injury and/or property damage.

### KVS v2.00

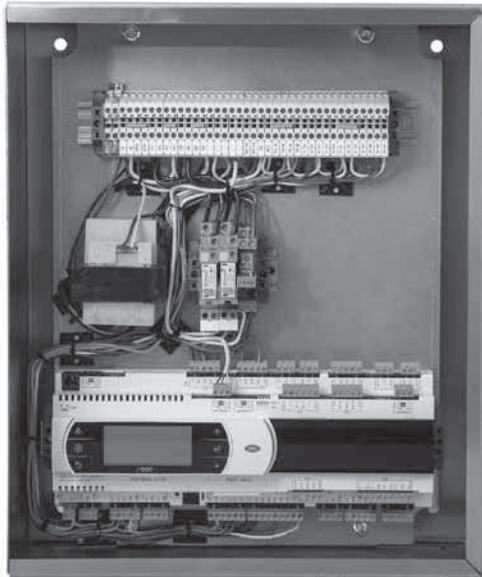

## General Safety Information

Only qualified personnel should install this product. Personnel should have a clear understanding of these instructions and should be aware of general safety precautions. Improper installation can result in electric shock, possible injury due to coming in contact with moving parts, as well as other potential hazards. If more information is needed, contact a licensed professional engineer before moving forward.

1. Follow all local electrical and safety codes, as well as the National Electrical Code (NEC) and the latest edition of the National Fire Protection Agency Standard for Ventilation Control and Fire Protection of Commercial Cooking Operations (NFPA 96). Follow the Canadian Electrical Code (CEC) and ULC-S650 if installing this product in Canada.
2. Do not allow the electrical components of this unit to come in contact with oil, grease, hot surfaces, water, or chemicals. Replace cord immediately if damaged.
3. Verify the site can supply the necessary power for each fan and for the control panel.

### WARNING

Electrical shock hazard. Can cause equipment damage, personal injury or death. Service must only be performed by personal that are knowledgeable in the operation of the equipment being controlled.

### DANGER

Always disconnect power before working on or near the product. Lock and tag the disconnect switch or breaker to prevent accidental power up.





### CAUTION

When servicing the product, variable frequency drives may be hot enough to cause pain or injury. Allow motor to cool before servicing.

### CAUTION

It is the responsibility of the installer to make sure both electrical and gas appliances shut down in the event of a fire or in the event of a power loss to the building when this sequence is required by the authority having jurisdiction.

# Table of Contents

- Receiving and Handling . . . . . 2
- Installation
  - Control Box Mounting . . . . . 3
  - Resistive Temperature Detector . . . . . 3
- Pneumatic Static Pressure Kit . . . . . 4
- Keypad Mounting, Diagram and Dimensions . . . . . 4
- Touch Screen Mounting, Diagram and Dimensions . . . . . 5
- Electrical Connections
  - Power for Vari-Flow Cabinet . . . . . 5
  - Power for Lights . . . . . 5
  - Variable Frequency Drives (VFD) . . . . . 6
  - Vari-Green® Fan Wiring . . . . . 6
  - VFD Provided by Others, Control Wiring . . . . . 6
  - Make-Up Air VFD in Vari-Flow Wiring . . . . . 6
  - Make-Up Air VFD in Make-Up Air Wiring . . . . . 7
  - Auto Tempering . . . . . 7
  - Fire System Microswitch . . . . . 7
  - Temperature Sensor(s) . . . . . 7-8
  - Keypad . . . . . 8
  - Touch Screen . . . . . 8
  - Remote Enable . . . . . 8
  - Shunt Trip . . . . . 8
  - Electric Gas Valve with Gas Reset . . . . . 8
  - Spare Fire Relay Contacts . . . . . 8
  - Grease Trapper Pollution Control Unit (PCU)
    - Filter Status . . . . . 9
    - ESP Linked . . . . . 9
  - High Temperature Alarm Contacts . . . . . 9
  - Airflow Proving Switch(es) . . . . . 9
- Vari-Flow Connection Checklist . . . . . 10
- Sequence of Operation . . . . . 11-12
- System Optimization . . . . . 12
- Controller Setup and Tutorial . . . . . 13-14
- Menus
  - A.  Fan Status . . . . . 15
  - B.  Clock . . . . . 16
  - C.  Input/Output . . . . . 16
  - D.  Service . . . . . 17-23
  - E.  Manufacturer . . . . . 23-25
- Keypad Navigation . . . . . 26
- Touch Screen Navigation . . . . . 27-31
  - General Information . . . . . 28
  - Settings . . . . . 28-29
  - Configuration . . . . . 30
  - Information . . . . . 31
- Troubleshooting . . . . . 32-33
- Variable Frequency Drive (VFD) Information . . . . . 34
  - Model V1000 Changing Parameters and Monitor
    - Motor Frequency and Motor Current . . . . . 35
  - Model A1000 Changing Parameters and Monitor
    - Motor Frequency and Motor Current . . . . . 35
- Building Management System (BMS) Points List
  - Vari-Flow v1.02 Modbus/BACnet® . . . . . 36-38
  - Vari-Flow v1.02 LonWorks® . . . . . 39-40
- Our Commitment . . . . . Backcover

# Receiving and Handling

## Receiving

Upon receiving the product, check to make sure all items are accounted for by referencing the bill of lading to ensure all items were received. Notify the carrier if any damage is noticed. The carrier will make notification on the delivery receipt acknowledging any damage to the product. All damage should be noted on all of the copies of the bill of lading which is countersigned by the delivering carrier. If damaged upon arrival, file a claim with the carrier. Any physical damage to the unit after acceptance is not the responsibility of the manufacturer.

## Unpacking

Verify that all required parts and the correct quantity of each item have been received. If any items are missing, report shortages to your local representative to arrange for obtaining missing parts.

## Storage

If a vari-flow control panel must be stored prior to installation, it must be protected from dirt and moisture. Indoor storage is highly recommended.

### NOTE

Improper storage which results in damage to the unit will void the warranty.

## Handling

Make sure the equipment does not suffer any heavy vibration or knocks.



# Installation

## Control Box Mounting

1. Locate an area with enough space to mount the control box and fasten to the wall.

### NOTE

Control box may be factory mounted. If so, continue to the next section.

### NOTE

If the Vari-Flow is equipped with static pressure control, it will be located in the panel. Therefore, this control box should be mounted in the space to be controlled. Refer to the Pneumatic Static Pressure Kit section for installation instructions of the pressure sensor kit on page 4.

## Temperature Sensor(s) Mounting

### NOTE

Temperature sensor(s) may be factory installed. If so, continue to the next section.

1. Locate flat area(s) at the top interior of the hood in front of the filters, towards the front of the hood.

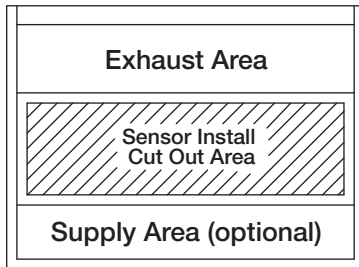

Top View of Exhaust Hood

2. Find a suitable location for the sensor in the flat space which will not interfere with the fire suppression nozzles and is not within 12 inches (304.8 mm) of any light fixtures. Cut a 3/4 to 7/8-inch (19.0 to 22.2 mm) diameter hole in the flat spot of the capture tank.

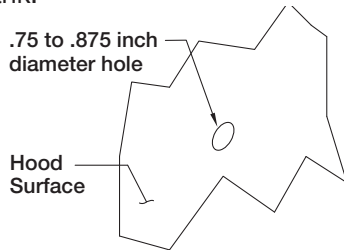

3. Center the octagon extension over the hole on the hood surface.

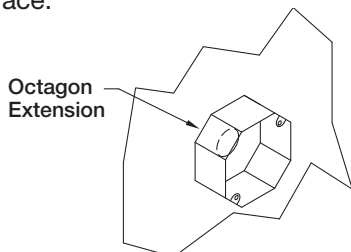

4. Insert the compression seal into the hole from the inside of the hood making sure the gasket is placed on the fitting before inserting it into the hole. Place the octagon box and J-box plate provided over the fitting on the top of the hood, keeping the fitting centered in the box. Install the lock washer and 1-1/2 inch (38.1 mm) nut on the threaded portion of the compression seal and tighten securely.

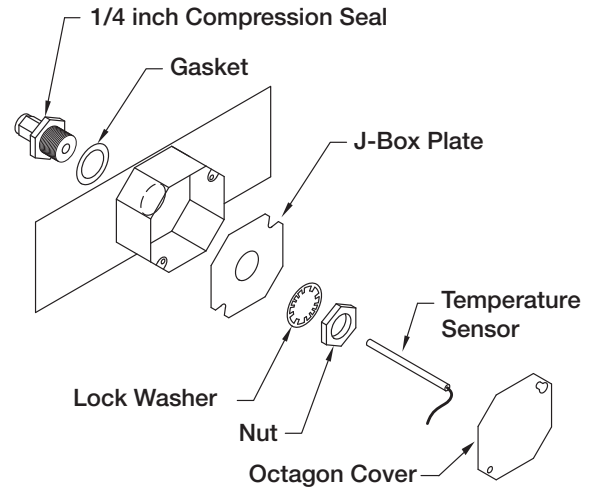

5. Insert the temperature sensor into compression seal and tighten to 35 ft-lbs (47.5 Nm).
6. Place octagon cover onto J-box plate and fasten it.

### NOTE

All field installation and wiring of electrical equipment must be done to meet NEC and local codes.

## Pneumatic Static Pressure Kit

- if equipped

### NOTE

The Vari-Flow system may not be provided with the static pressure controls. If not, move onto the next section.

1. Locate the Kele® static pressure sensor outside of the building in a secure location free from as many obstructions as possible.
2. Refer to the instruction manual with the static pressure sensor for installation and operation details.
3. Once the static pressure probe is mounted, run vinyl tubing from the probe back to the control panel and coil the excess tubing. Do not kink or trim the tubing.
4. If the control panel is located in the space to be controlled, go to the next section. If the control panel is mounted remotely from the space to be controlled, continue to step 5.
5. Run 1/4 inch virgin poly tubing (by others) from the sensor in the control panel to a secure location in the space to be controlled.

## Keypad Mounting - if equipped

### NOTE

The keypad may be factory mounted. If so, continue to the Electrical Connections section.

1. For systems with remote controls or keypad, a 35, 75, or 150 foot RJ25 cable is supplied to connect the keypad to the controls. The cable is plenum rated and does not need to be run through conduit unless required by local codes. If the keypad is to be mounted further away than the cable that is received, additional cable will be needed. Additional cable is available at the lengths mentioned above.

### Keypad Mounting Diagram

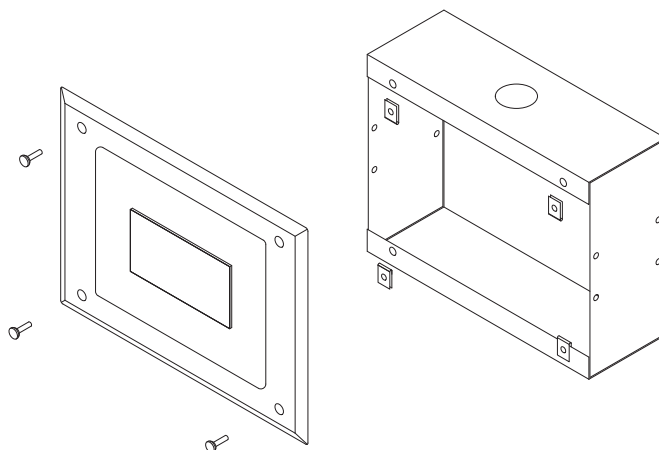

### Keypad Dimensions

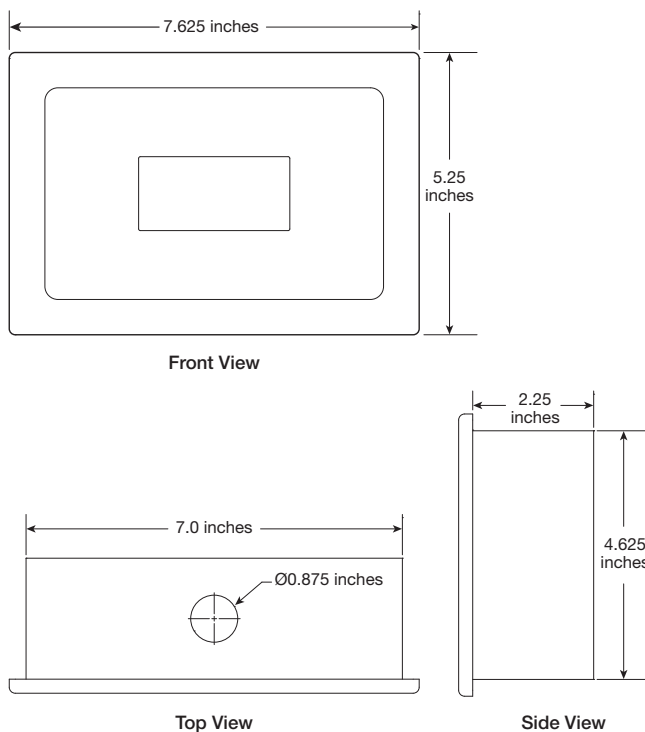

## Touch Screen Mounting - if equipped

### NOTE

The touch screen may be factory mounted. If so, continue to the Electrical Connections section.

- For systems with remote controls or touch screen, two 35, 75, or 150 foot sets of cables are supplied to connect the touch screen to the controls. The cables are plenum rated and do not need to be run through conduit unless required by local codes. If the keypad is to be mounted further away than the cable that is received, additional cable will be needed. Additional cables are available at the lengths mentioned above.

### Touch Screen Mounting Diagram

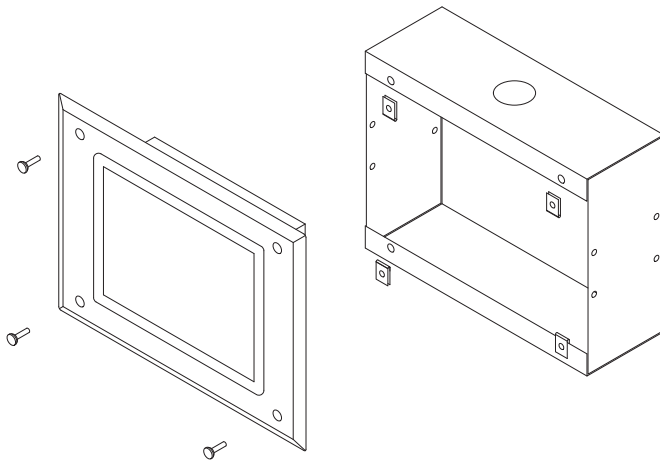

### Touch Screen Dimensions

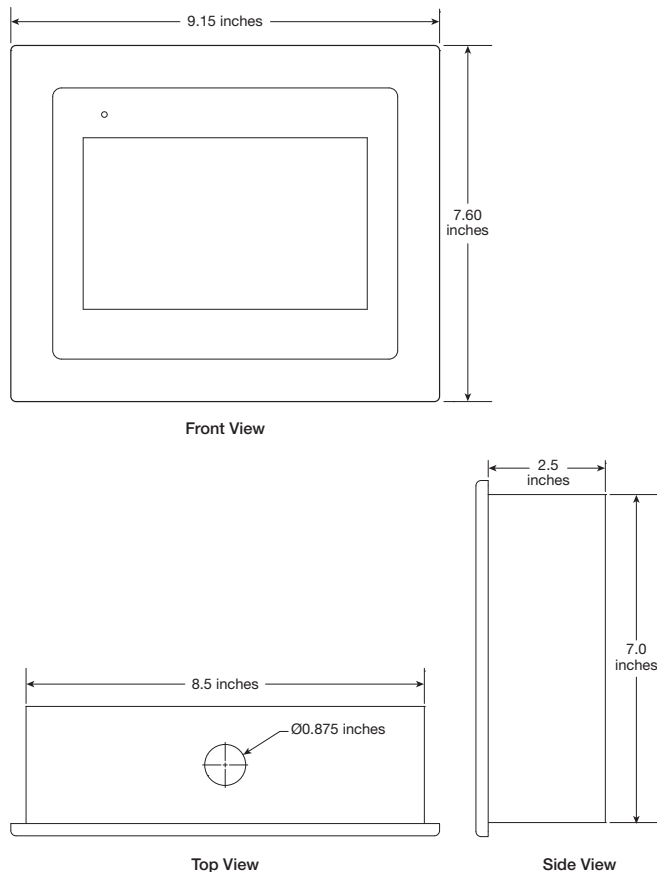

## Electrical Connections

### NOTE

All wiring of electrical equipment must be done to meet NEC and local codes.

### NOTE

It is recommended that shielded wire be used for all low voltage connections (24V or less) to prevent signal interference with other high voltage circuits.

### NOTE

All 115 VAC field wiring (or higher) must be routed through hard or flex conduit. All low voltage field wiring should be plenum rated if not routed through conduit. Field wiring should not come in contact with the surface of the hood. To reduce the likelihood of electromagnetic disturbance, avoid routing high and low voltage cables in the same conduit.

### Power for Vari-Flow Cabinet

- 115 VAC, power for controls (Terminals H and N)

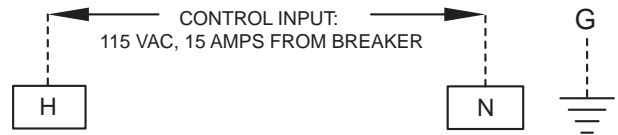

### Power for Lights

- 115 VAC, power **for** hood lights, one per light circuit (Terminals H1, N1 | H2, N2 | H3, N3 | H4, N4)
- 115 VAC, power **to** lights, one per light circuit (Terminals B1, W1 | B2, W2 | B3, W3 | B4, W4)

### EACH CANOPY LIGHTING CIRCUIT MUST NOT EXCEED 15A TOTAL CURRENT

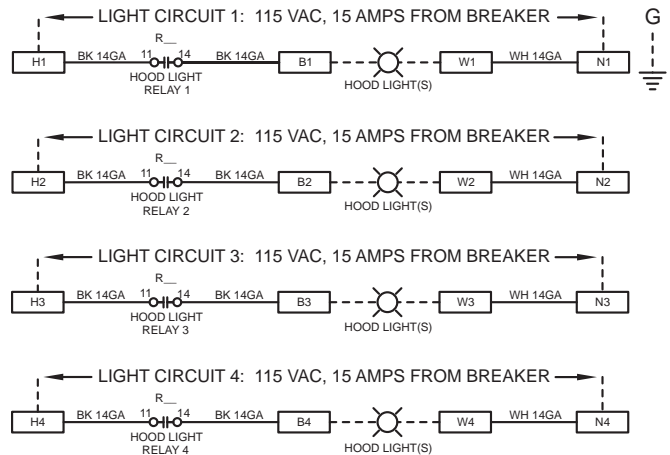

**Variable Frequency Drives (VFD) - if equipped**

**NOTE**

If electrically commutated motors are being used, VFDs will not be needed.

1. Bring power to the input of each VFD from a dedicated power source using conduit to the NEMA-1 enclosure on the bottom of the drive. Each power source shall be of the same voltage as the respective fan and of a high enough amp rating to handle the full load amp draw of the respective fan.

**NOTE**

The VFD motor overload parameter (E2-01) needs to be set to match the motor nameplate FLA. Refer to the Quick Start Guide from Yaskawa, or the Variable Frequency Drive information found on pages 34-35 for setting these parameters on the drive.

**NOTE**

Be sure to use appropriately sized wire for the full load amp draw.

2. To avoid interference between the conductors, separate conduit from the VFD output to the input power of the fan must be used for each fan.

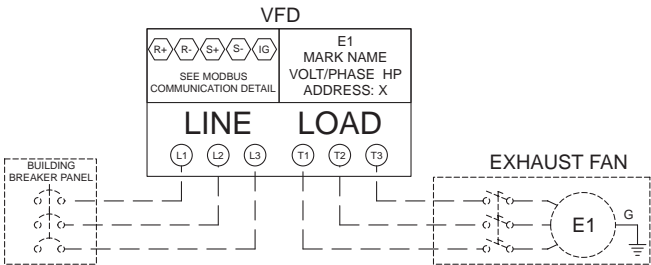

Each variable frequency drive must have the LINE and LOAD wiring in separate conduit.

**Vari-Green® Fan Wiring - if equipped**

- 24 VAC from Vari-Flow to Vari-Green motor control wire, black (Terminal E\_\_24)
- 0-10 VDC Speed Reference from Vari-Flow to Vari-Green motor control wire, red (Terminal E\_\_S+)
- Common from Vari-Flow to Vari-Green motor control wire, white (Terminal E\_\_S-)

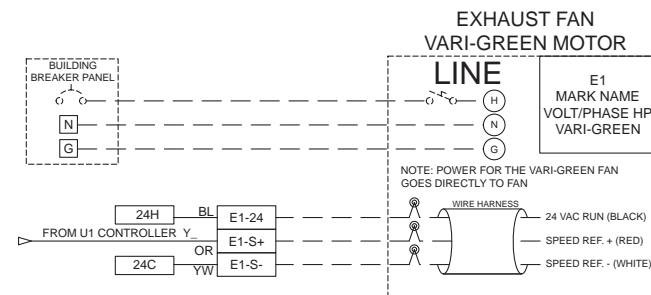

This is an example of Exhaust Fan 1 provided with Vari-Green motor.

**NOTE**

Some Vari-Green motors do not require the 24 VAC wire.

**VFD Provided by Others, Control Wiring - if equipped**

- Fault command from Vari-Flow to VFD provided by others (Terminal E\_\_-FA, E\_\_-FB)
- Run command from Vari-Flow to VFD provided by others (Terminal E\_\_-RA, E\_\_-RB)
- Speed reference from Vari-Flow to VFD provided by others (Terminal E\_\_S+, E\_\_S-)
- Line power to VFD
- Load power from VFD to fan

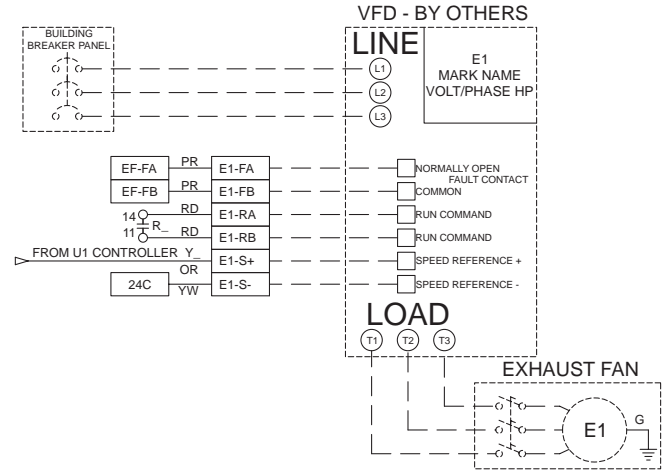

This is an example of Exhaust Fan 1 provided with a VFD by others.

**NOTE**

If the VFD by others is a supply fan, control terminals will begin with a 'S' instead of an 'E'.

**Make-Up Air VFD in Vari-Flow Wiring - if equipped**

- 24 VAC run command from Vari-Flow to make-up air unit (Terminals S\_\_-42, )
- Tempering status from Vari-Flow to make-up air unit (Terminals S\_\_-44, S\_\_-45)
- Line power to VFD input, bottom left of VFD (Terminals L1, L2, L3)
- Load power from VFD output, bottom right of VFD to make-up air disconnect (Terminals T1, T2, T3)

Make-up air unit requires separate 115 VAC or 3-phase control power circuit. See the MUA wiring diagram for details.

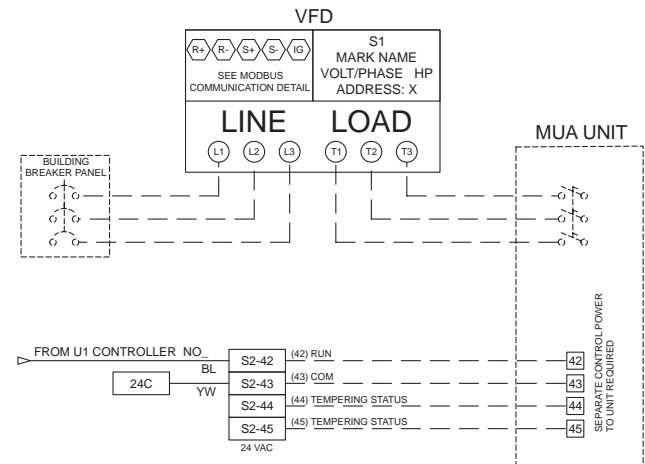

This is an example of Supply Fan 1 being a make-up air with VFD in the Vari-Flow panel.



### Make-Up Air VFD in Make-Up Air Wiring - if equipped

- 24 VAC run command from Vari-Flow to make-up air unit (Terminals S\_\_-42, S\_\_-43)
- Tempering status from Vari-Flow to make-up air unit (Terminals S\_\_-44, S\_\_-45)
- 0-10 VDC speed reference from Vari-Flow to make-up air unit (Terminals S\_\_-46, S\_\_-47)

Power for make-up air goes directly to make-up air unit.

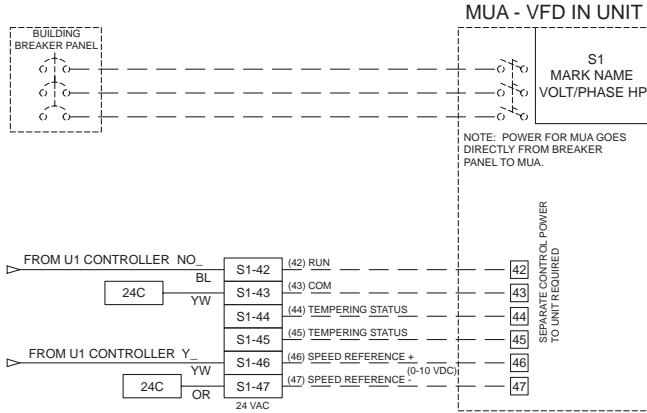

This is an example of Supply Fan 1 being a make-up air with VFD in the make-up air unit.

### Auto Tempering - if equipped

- Auto Heat/Cool enable (Terminals S1-R, S1-W1, S1-Y1)

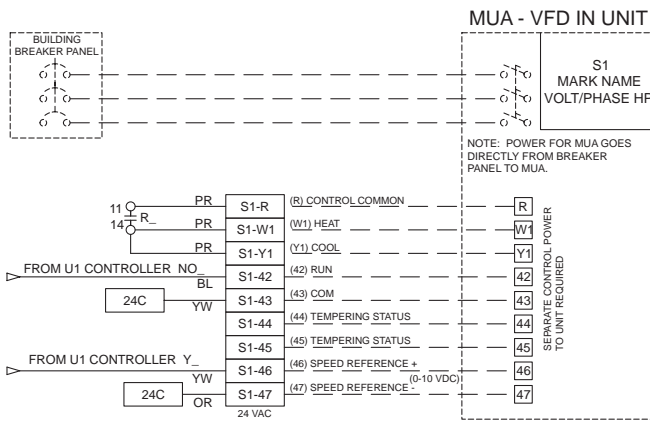

This is an example of Supply Fan 1 with auto tempering (VFD in make-up air unit).

### Fire System Microswitch

- Fire system microswitch common to Vari-Flow (Terminal C1)
- Fire system microswitch normally closed contact to Vari-Flow (Terminal NC1)

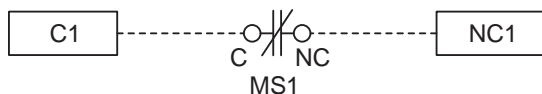

### Temperature Sensor(s)

Wire the two leads of the sensors to be designated terminals in the control panel as shown below. This is determined by the number of temperature sensors on the job (1-10 sensors). The two wires of the sensor are not polarity sensitive. If more than one hood is being controlled, be sure that the appropriate sensor is wired to the appropriate terminals as depicted on the job specific wiring diagram.

#### CAUTION

Each sensor is a low voltage, resistive temperature detector. They are not a high voltage switch/thermostat. Do not connect temperature sensors in series/parallel with high voltage. This can result in damage to the temperature sensor and will require replacement.

#### NOTE

Each temperature sensor is rated up to 250°F (121.1°C) and therefore should not be exposed to direct flame. Exposing sensors to direct flame may render the sensor inoperable and replacements will not be covered under warranty.

### Temperature Sensor(s)\* - installed in hood

- Temperature Sensor T1 to Vari-Flow (Terminals T1-A, T1-B)

Refer to table (example on following page) to cross reference the temperature sensor and the hood mark.

\*Repeat based on the number of temperature sensors. (Terminals T2-A, T2-B | T3-A, T3-B | T4-A, T4-B | T5-A, T5-B | T6-A, T6-B | T7-A, T7-B | T8-A, T8-B | T9-A, T9-B | T10-A, T10-B)

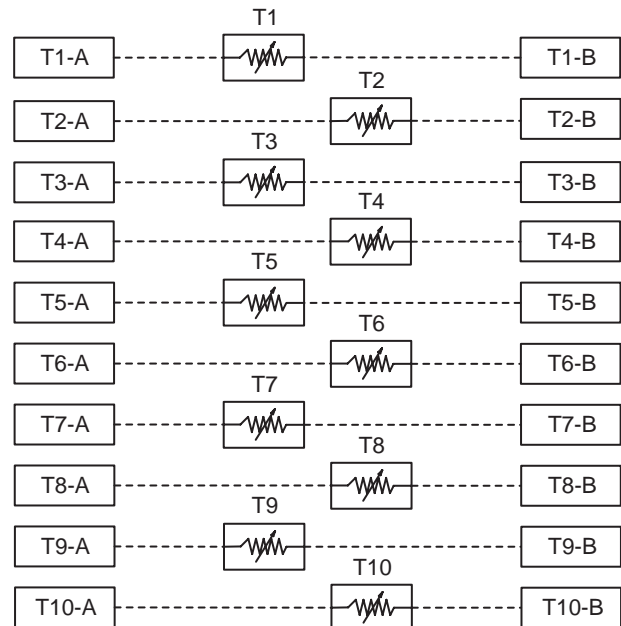

NOTE: The Vari-Flow job specific temperature sensor table is found in the wiring diagram located on the Vari-Flow panel door. This table is an example, do not use for your specific job.

Sensors (Field Wiring)		Related Fans	
Sensor	Hood Mark	Exhaust Fans	Supply Fans
T1	Hood Mark Name 1	F1-E	F11-S
T2	Hood Mark Name 2	F2-E	F11-S
T3	Hood Mark Name 3	F3-E	F12-S
T4	Hood Mark Name 4	F4-E	F12-S
T5	Hood Mark Name 5	F5-E	F12-S
T6	Hood Mark Name 6	F6-E	F13-S
T7	Hood Mark Name 7	F7-E	F13-S
T8	Hood Mark Name 8	F8-E	F14-S
T9	Hood Mark Name 9	F9-E	F14-S
T10	Hood Mark Name 10	F10-E	F14-S

**Keypad - if equipped**

- Connect provided cable from back of keypad to CAREL® PCO5+ controller (Terminal J10)

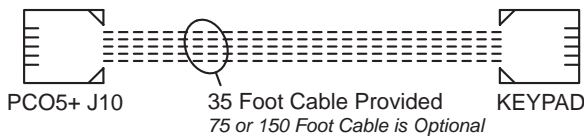

**Touch Screen - if equipped**

Power Wiring

- Connect provided 2-wire cable from Vari-Flow (Terminals TS24, TSC) to touch screen (Terminals G, GO)

Control Wiring

- Connect provided 3-wire cable from Vari-Flow (Terminals -, +, GND) to touch screen (Terminals -, +, GND)

**Power Wiring**

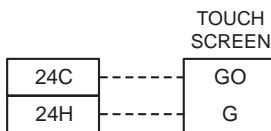

**Control Wiring**

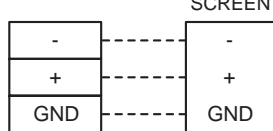

**Remote Enable - if equipped**

- Connect remote enable common and normally open from BMS to Vari-Flow (Terminals RE-1A, RE-1B)

A closed contact will turn on all fans.  
An open contact will turn off all fans.

**NOTE**

Temperature interlock will override the remote enable input.

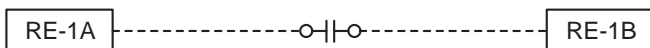

**Shunt Trip - if equipped**

- 115 VAC from Vari-Flow to shunt trip breaker coil (provided by others) (Terminals STH, STN)

Voltage across STH, STN when in fire will be 115 VAC  
Voltage across STH, STN when not in fire will be 0 VAC



**NOTE**

Shunt trip contacts will lose voltage during momentary losses in power to the Vari-Flow control cabinet, tripping the connected shunt trip breaker. If installed in areas with frequent losses in power, it is recommended that all shunt trip breakers be wired through a normally open (N.O.) contact of an additional fire system microswitch instead.

**Electric Gas Valve with Gas Reset - if equipped**

- 115 VAC from Vari-Flow to gas solenoid (Terminals SVH, SVN)

Voltage across SVH, SVN when in fire will be 0 VAC  
Voltage across SVH, SVN when not in fire and turn on will be 115 VAC

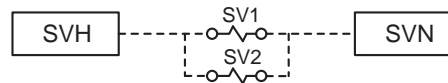

**Spare Fire Relay Contacts - if equipped**

- Power to common (Terminal C3)
- Power out, normally open, closed in fire (Terminal NO3)
- Power out, normally closed, open in fire (Terminal NC3)
- Power to common (Terminal C4)
- Power out, normally open, closed in fire (Terminal NO4)
- Power out, normally closed, open in fire (Terminal NC4)

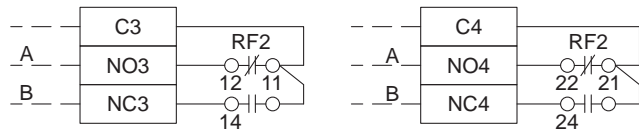

- A < OPEN WITH POWER AT H & N & FIRE SYSTEM ARMED  
CLOSED ON FIRE OR NO POWER
- B < CLOSED WITH POWER AT H & N & FIRE SYSTEM ARMED  
OPEN ON FIRE OR NO POWER





**Grease Trapper Pollution Control Unit (PCU) Filter Status - if equipped**

- PCU filter 24VAC hot from terminal FH in enclosure on the access side of the unit to Vari-Flow (Terminal FH)
- PCU filter 1 module status from terminal F1 in enclosure on access side of the unit to Vari-Flow (Terminal F1)
- PCU filter 2 module status from terminal F2 in enclosure on access side of the unit to Vari-Flow (Terminal F2)
- PCU filter 3 module status from terminal F3 in enclosure on access side of the unit to Vari-Flow (Terminal F3)

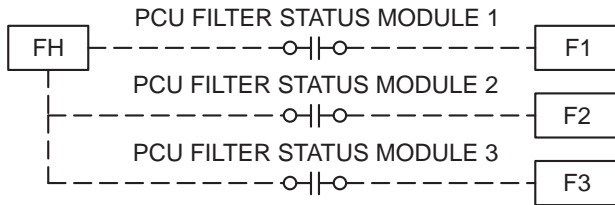

**High Temperature Alarm Contacts - if equipped**

- Power to common (Terminal HT-C)
- Power out, normally closed, open in high temperature alarm (Terminal HT-NC)
- Power out, normally open, closed in high temperature alarm (Terminal HT-NO)

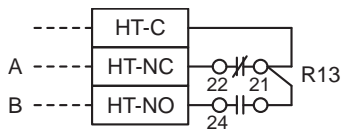

- A: Closed with power at H & N and high temperature alarm inactive, closed with no power
- B: Open with power at H & N and high temperature alarm active, open with no power

**Airflow Proving Switch(es) (provided by others) - if equipped**

- Common and normally open from supply fan 1 air proving switch to Vari-Flow (Terminals AP-1A, AP-1B)
- Common and normally open from supply fan 2 air proving switch to Vari-Flow (Terminals AP-2A, AP-2B)
- Common and normally open from supply fan 3 air proving switch to Vari-Flow (Terminals AP-3A, AP-3B)
- Common and normally open from supply fan 4 air proving switch to Vari-Flow (Terminals AP-4A, AP-4B)

NOTE: Airflow proving switch(es) are not provided with the Vari-Flow system.

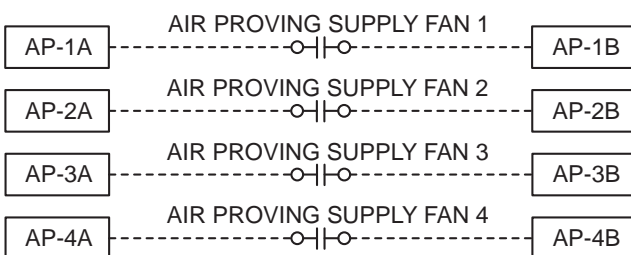

**Grease Trapper ESP Linked - if equipped**

- E1-RA & E1-RB provides a dry contact closure for the run command on RE-1A & RE-1B of the ESP.
- E1-S+ provides 0-10V speed reference on SPD-+ of the ESP
- E1-S- provides 24V common reference on SPD-C of the ESP
- C2 & NC2 fire mode reference on C1 & NC1 of the ESP
- WS-2A & WS-2B wash reference on C6 & NC6 of the ESP

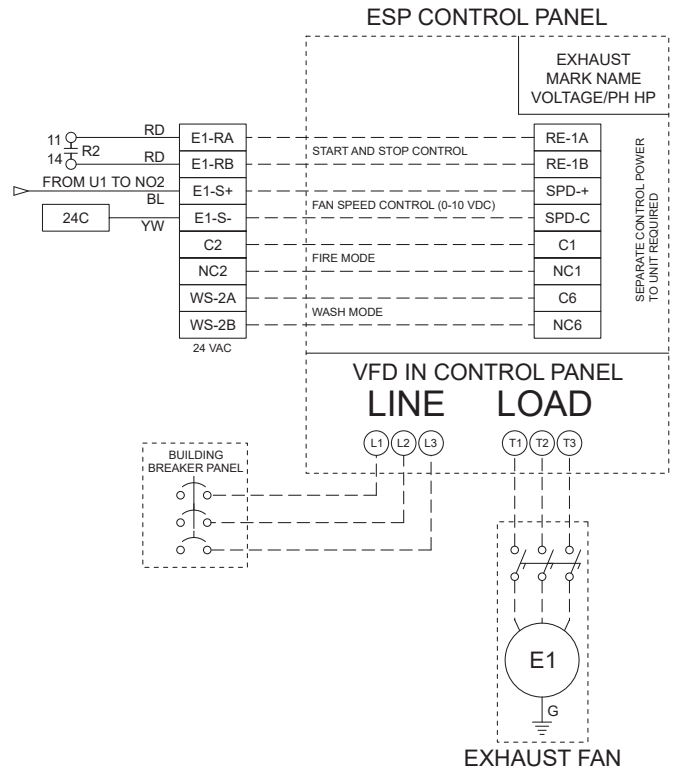

# Vari-Flow Connection Checklist

## Power for Vari-Flow Cabinet

- Connect 115 VAC power for controls (Terminals H, N)
- Connect 115 VAC power for hood lights, one per light circuit (Terminals H1, N1 | H2, N2 | H3, N3 | H4, N4)
- Connect 115 VAC power to lights, one per light circuit (Terminals B1, W1 | B2, W2 | B3, W3 | B4, W4)

## Power to Variable Frequency Drives (VFD)\*

- Line power to VFD input, bottom left of VFD (Terminals L1, L2, L3)
- Load power from VFD output, bottom right of VFD (Terminals T1, T2, T3)

## Vari-Green® Fan Wiring\* - if equipped

- 24 VAC from Vari-Flow to Vari-Green motor control wire, black (Terminal E\_\_-24)  
*Not required on 2 HP Vari-Green motors*
- 0-10 VDC Speed Reference from Vari-Flow to Vari-Green motor control wire, red (Terminal E\_\_S+)
- Common from Vari-Flow to Vari-Green motor control wire, white (Terminal E\_\_S-)

## VFD Provided by Others, Control Wiring\* - if equipped

- Fault command from Vari-Flow to VFD provided by others (Terminal E\_\_-FA, E\_\_-FB)
- Run command from Vari-Flow to VFD provided by others (Terminal E\_\_-RA, E\_\_-RB)
- Speed reference from Vari-Flow to VFD provided by others (Terminal E\_\_S+, E\_\_S-)
- Line power to VFD
- Load power from VFD to fan

## Make-Up Air VFD in Vari-Flow Wiring\* - if equipped

- 24 VAC run command from Vari-Flow to make-up air unit (Terminals S\_\_-42, S\_\_-43)
- Tempering status from Vari-Flow to make-up air unit (Terminals S\_\_-44, S\_\_-45)
- Line power to VFD input, bottom left of VFD (Terminals L1, L2, L3)
- Load power from VFD output, bottom right of VFD to make-up air disconnect (Terminals T1, T2, T3)

## Make-Up Air VFD in Make-Up Air Wiring\* - if equipped

- 24 VAC run command from Vari-Flow to make-up air unit (Terminals S\_\_-42, S\_\_-43)
- Tempering status from Vari-Flow to make-up air unit (Terminals S\_\_-44, S\_\_-45)
- 0-10 VDC speed reference from Vari-Flow to make-up air unit (Terminals S\_\_-46, S\_\_-47)

## Auto Tempering - if equipped

- Auto Heat/Cool enable (Terminals S1-R, S1-W1, S1-Y1)

## Fire System Microswitch

- Fire system microswitch common to Vari-Flow (Terminal C1)
- Fire system microswitch normally closed contact to Vari-Flow (Terminal NC1)

## Resistive Temperature Sensors\* - installed in hood

- Temperature Sensor T1 (Terminals T1-A, T1-B)  
*If more than one temperature sensor is used, wire the following if applicable:*
- Temperature Sensor T2 (Terminals T2-A, T2-B)
- Temperature Sensor T3 (Terminals T3-A, T3-B)
- Temperature Sensor T4 (Terminals T4-A, T4-B)
- Temperature Sensor T5 (Terminals T5-A, T5-B)
- Temperature Sensor T6 (Terminals T6-A, T6-B)

- Temperature Sensor T7 (Terminals T7-A, T7-B)
- Temperature Sensor T8 (Terminals T8-A, T8-B)
- Temperature Sensor T9 (Terminals T9-A, T9-B)
- Temperature Sensor T10 (Terminals T10-A, T10-B)

## Keypad - if equipped

- Connect provided RJ25 cable from back of keypad to CAREL® PCO5+ (Terminal J10).

## Touch Screen - if equipped

- Connect provided 2-wire cable from Vari-Flow (Terminals TS24, TSC) to touch screen (Terminals G, GO)
- Connect provided 3-wire cable from Vari-Flow (Terminals -, +, GND) to touch screen (Terminals -, +, GND)

## Remote Enable- if used

- Connect remote enable common and normally open from BMS to Vari-Flow (Terminals RE-1A, RE-1B)

## Shunt Trip - if used

- 115 VAC from Vari-Flow to shunt trip breaker coil (provided by others) (Terminals STH, STN)

## Electric Gas Valve with Gas Reset - if equipped

- 115 VAC from Vari-Flow to gas solenoid (Terminals SVH, SVN)

## Spare Fire Relay Contacts - if equipped

- Power to common (Terminal C3)
- Power out, normally open, closed in fire (Terminal NO3)
- Power out, normally closed, open in fire (Terminal NC3)
- Power to common (Terminal C4)
- Power out, normally open, closed in fire (Terminal NO4)
- Power out, normally closed, open in fire (Terminal NC4)

## Grease Trapper Pollution Control Unit (PCU)

### Filter Status - if equipped

- PCU filter status 24 VAC hot (FH)
- PCU filter 1 module status (F1)
- PCU filter 2 module status (F2)
- PCU filter 3 module status (F3)

## High Temperature Alarm Contacts - if equipped

- Power to common (Terminals HT-C)
- Power out, normally closed, open in high temperature alarm (Terminal HT-NC)
- Power out, normally open, closed in high temperature alarm (Terminal HT-NO)

## Air Proving Switch(es) (provided by others) - if equipped

- Common and normally open from supply fan 1 air proving switch to Vari-Flow (Terminals AP-1A, AP-1B)
- Common and normally open from supply fan 2 air proving switch to Vari-Flow (Terminals AP-2A, AP-2B)
- Common and normally open from supply fan 3 air proving switch to Vari-Flow (Terminals AP-3A, AP-3B)
- Common and normally open from supply fan 4 air proving switch to Vari-Flow (Terminals AP-4A, AP-4B)

**\*Wiring repeated based on the number of fans of that type. This is based on the job specific Vari-Flow wiring diagram.**

# Sequence of Operation

## Normal Operation

1. Press the ALL HOODS button on the keypad or the ALL HOODS ON/OFF button on the touch screen to turn the fans on (manual mode).
  - a. Vari-Flow will turn on all exhaust and supply fans.
  - b. The Vari-Flow system starts the fans at idle speeds between the low speed setpoint (50% default) and high speed setpoint (100% default) based on actual cooking loads as sensed by the temperature sensors mounted in the hood capture area. This is determined by the low temperature setpoint (90°F default) and high temperature setpoint (115°F default).
  - c. The Vari-Flow system adjusts the supply speed based on a weighted average of the exhaust fan speed. If static pressure sensor is used for supply airflow control it will adjust the supply speed based on static pressure.
  - d. If the keypad was configured for individual fan/light control, pressing the HOODS button (or INDIVIDUAL HOOD SYSTEM ON/OFF button on the touch screen) will navigate to screens where individual hood system control will be available.
2. Press the ALL HOODS button on the keypad or the ALL HOODS ON/OFF button on the touch screen again to turn off the fans.
  - a. Only if all of the fans are on will pressing the ALL HOODS or ALL HOODS ON/OFF button shut off all of the fans.
  - b. The Vari-Flow system may go into auto mode if conditions 3.a-3.c are met.
3. Temperature interlock mode (auto mode).
  - a. If the temperature in the hood goes above the temperature interlock on setpoint (115°F default) and the fans are currently off, the Vari-Flow will automatically turn on the associated exhaust and/or supply fans.
  - b. If the temperature in the hood goes below the temperature interlock off setpoint (90°F default) and the fans are not currently turned on manually the fans will turn off after the temperature interlock off delay time setpoint (10 minute default).
  - c. If the fans were turned on manually and the user attempts to turn off the fans with the hood temperature not meeting condition b the fan(s) will remain on until such conditions are met.
4. With the fan(s) on via manual or auto mode, pressing the FAN 100% button on the keypad (100% OVERRIDE ON/OFF button on the touch screen) will force the exhaust fan(s) that are currently on to full speed for the 100% override off delay setpoint. The supply fan will adjust speed the same as 1.c.
5. Pressing the FAN 100% button on the keypad (100% OVERRIDE ON/OFF button on the touch screen) will turn the 100% override off and return the fans to the speed as discussed in 1.b.
6. Pressing the ALL LIGHTS button on the keypad or the ALL LIGHTS ON/OFF on the touch screen will turn on all the hood lights.
  - a. If the keypad was configured for individual fan/light control, pressing the LIGHTS button (or INDIVIDUAL LIGHT ON/OFF button on the touch screen) will navigate to screens where individual light circuit control will be available.
7. Pressing the LIGHTS button on the keypad or ALL LIGHTS ON/OFF button on the touch screen again will turn off all of the hood lights.
  - a. Only if all the hood lights are currently on will pressing the LIGHTS or ALL LIGHTS ON/OFF button shut off all of the hood light circuits.
8. *If equipped*, on the keypad, pressing the MORE button will navigate to additional screens. Pressing the BACK button will navigate back to the previous screen.
9. *If equipped*, pressing the GAS RESET button on the keypad (or GAS RESET ON/OFF button on the touch screen) will open the electric gas valve to allow gas to flow to the appliances. Once gas has been reset, it cannot be manually shut off by this button. It will remain enabled until an alarm condition such as high temperature or fire is detected, or the control panel power is reset.

### WARNING

Make sure after opening the electric gas valve that all pilot lights (if appliances have standing pilots) are lit. Failing to relight pilots will cause gas to flow into the kitchen.

10. *If equipped*, pressing the AUTO TEMP button on the keypad (or AUTO TEMPERING ON/OFF button on the touch screen) will enable automatic tempering of the MUA unit. When this is on, the make-up air will heat/cool the air as determined by the inlet air sensors. When this is off, the make-up air heating/cooling will be disabled.

## Sequence of Operation, *continued*

### Fire Operation:

1. With the fire system microswitch wired to terminal C1 and NC1 (normally closed contact) and the fire system in a fire state, the following will occur:
  - a. System alarm will appear on keypad or touch screen.
  - b. Vari-Flow will force the exhaust fan(s) to full speed. (Factory default, but can be adjusted in the service menu).
  - c. Vari-Flow will force the supply fan(s) off. (Factory default, but can be adjusted in the service menu).
  - d. Vari-Flow will send 115 VAC signal to shunt trip breaker coil (Breaker provided by others).
  - e. Vari-Flow will force the lights off. (If selected with lights out in fire option).
  - f. Vari-Flow will force the electric gas valve off. (If selected with gas valve reset option).

### Alarm Operation:

Upon any system alarm, the red system fault LED will flash on the keypad (red alarm indicator will flash on the touch screen). Once the alarm is corrected, the LED/indicator will stop flashing. A list of alarms is shown below:

1. Kitchen fire alarm.
2. Temperature sensor fault.
  - a. Associated fan(s) will be turned on and forced to full speed until fault is rectified.
3. Exhaust or supply VFD alarm - *if equipped*.
4. Supply airflow proving fault - *if equipped*.
  - a. Exhaust fans will not turn on until supply airflow has been proven. It will remain this way until the fault is rectified.
5. Pressure sensor fault - *if equipped*.
  - a. Supply fan speed will automatically be controlled via weighted average until the fault is rectified.
6. High temperature alarm - *if equipped*.
  - a. Vari-Flow will send 115 VAC signal to shunt trip breaker coil (breaker provided by others).
  - b. Vari-Flow will force the electric gas valve off (if selected with gas valve reset option).
7. PCU filter status alarm - *if equipped*.

### NOTE

When initially triggered, all alarms will be logged into the alarm logger on the controller.

## System Optimization

### Setting the Low Temperature Set Point (90°F default)

**NOTE:** If the system is provided with a keypad, press the Prg button (Ⓞ) for 5 seconds to enter the main menu.

1. Go to the Service menu. Press Enter button.
2. Go to the Setpoints menu. Press Enter button.
3. Insert service password (default 1000).
4. Press down until you find the Exhaust Fan Setpoints.
5. Current temp that is controlling that fan will be displayed at the bottom of the screen. Adjust the Low Temp to be 5 - 10 degrees above this temperature.

### Setting the High Temperature Set Point (115°F default)



1. Turn the fans on via the keypad or touchscreen.
2. Turn on all cooking appliances (on highest setting) and allow them to reach normal cooking temperatures.
3. Go to the Service menu. Press Enter button.
4. Go to the Setpoints menu. Press Enter button.
5. Insert service password (default 1000).
6. Press down until you find the Exhaust Fan Setpoints.
7. Current temp that is controlling that fan will be displayed at the bottom of the screen. Adjust the High Temp to be 5 - 10 degrees below this temperature.

# Controller Setup and Tutorial







The user can access the main menu by pressing the  button.

Within the programmable logic controller, factory set points can be modified to configure the system for specific functions if necessary. All parameters are shown in this section.





Some of the menus require the user to enter a password in order to enter the menu. The service password is 1000 and is entered by pressing the   and  buttons.

The DDC controller is located in the unit control panel. The face of the controller has six buttons, allowing the user to view unit conditions and alter parameters. The DDC controller is pre-programmed with easy to use menus.

To change the display contrast, hold the Alarm  and Program  buttons simultaneously while pressing the  and  arrows.

If equipped, the keypad user interface connects via a factory-provided RJ-25 cable to the J10 port on the controller.

Information regarding most of the settings within the Controller U1 are provided in this Installation, Operation and Maintenance Manual.



Keypad Navigation		
	Escape	Allows the user to exit the current menu, jumping to the Main Menu.
	Up   Down	The arrow buttons allow the user to scroll through different screens and adjust parameters.
	Alarm	Button will blink red, indicating an alarm condition. Press to review current alarms. To review previous alarms, access the DATA LOGGER in the alarm menu.
	Enter	A. In screens with adjustable parameters, pressing the Enter button moves the cursor from the upper left corner of the screen to the parameter. The arrow buttons can then be used to adjust the parameter. B. To move to the next parameter on the same screen, press the Enter button. C. To save the change, press the Enter button until the cursor moves back to the upper left corner of the screen.
	Program	Pressing the Program button allows the user to enter the Main Program Menu.

## Example of Parameter Adjustment

Exhaust 1 Setpoints		
	Temp	Speed
Low:	90.0°F	50.0%
High:	115.0°F	100.0%
Current Temp:	70.0°F	

Once you enter into a menu that has adjustable parameters, the cursor always begins in the upper left corner of the display and will be blinking. Press the  button to move the cursor down for parameter adjustment.

Exhaust 1 Setpoints		
	Temp	Speed
Low:	90.0°F	50.0%
High:	115.0°F	100.0%
Current Temp:	70.0°F	

Once the cursor has reached the desired parameter, press the   buttons to adjust the value.

Exhaust 1 Setpoints		
	Temp	Speed
Low:	90.0°F	50.0%
High:	115.0°F	100.0%
Current Temp:	70.0°F	

When satisfied with the adjustment, press the  button to save the parameter. **When finished, make certain the cursor is in the upper left corner. If the cursor is not in the upper left corner, the changes will not be saved.** The cursor must be in the upper left corner to enable screen advancement.

## Main Menu Overview

If the Vari-Flow panel is configured with a touch screen, the controller will revert back to a kitchen hood status loop. This loop includes several screens to view the operating conditions of the unit. If configured, scroll through the menu screens by using  $\uparrow$   $\downarrow$  buttons. **Screens with a dashed line border are dependent upon the configuration and may not appear for every system.**

TIME	DATE	UNIT##
Kitchen Hood 1		Speed
XXX°F		XXX%
Hood System 1		
Status: OFF		
*No Supply Airflow		

### KITCHEN HOOD #1 STATUS:

The temperature on this screen displays real-time conditions from the sensors located in the hood. The speed on this screen displays the real-time conditions of the fans exhausting this hood.

“Hood System 1” describes the hood system that this particular hood is part of; hoods that are exhausted from the same exhaust fan will be linked to a hood “system”.

The “Status” indicator will display the following hood statuses:

- ON: Hood has been turned on; fans controlling the hood are operational.
- ON by Temp: Hood has been turned on by temperature interlock/high temperatures in the hood.
- ON by Alarm: Hood has been turned on due to an alarm.
- OFF: Hood is off; fans controlling the hood are not running.
- FIRE: Kitchen fire has been detected under one of the hoods.

If the airflow proving option is included, the hoods have been turned on, and supply airflow is not detected, “No Supply Airflow” will be displayed on the screen (see example).

## Example of Alarms

If an alarm occurs, the  button will flash red on the controller and the keypad (if connected).

Alarms
Press DOWN to review current alarm(s).
Press ESC to exit.
Press ALARM to reset.

To navigate to the alarm menu, press the  button once. Press the  $\downarrow$  button to scroll through any current alarms. Once the problem causing the alarm has been corrected, the alarm will automatically clear. If the alarm cannot be cleared, the cause of the alarm has not been fixed.

*** ALARM ***
Temp Sensor Input 1 Failure
Confirm sensor is connected to terminals T1-A & T1B.

This is an example of a hood temperature sensor failure.



Alarms
No active alarm
 Press ENTER key to access ALARM HISTORY log.

This screen appears if there are no active alarms.

To view all saved alarms, press the  $\leftarrow$  button to enter the DATA LOGGER. For more information, see the Data Logger menu.

Alarm	Alarm Description
Exhaust Fan Alarm	Failure of an exhaust VFD
Supply Fan Alarm	Failure of a supply VFD
Hood Sensor Input Failure	Failure of a hood temperature sensor
High Temperature Alarm	Indicates a high hood temperature
Pressure Sensor Input Failure	Indicates a pressure that is out of range
Supply Airflow Alarm	Indicates a loss of airflow in the supply fan
Kitchen Fire Detected/Alarm	Indicates a kitchen fire
YASKAWA V1000 ALM	Indicates a specific fault of factory provided VFD
Exhaust/Supply Fan Offline Alarm	Indicates a loss of communication to the VFD(s)
Grease Trapper PCU Filter Status Alarm	Indicates filter change required on Grease Trapper PCU

## Menus

The controller is equipped with several menus to help guide users with altering program parameters. The following menu can be accessed by pressing the  button. To enter the desired menu, press the  button.

### A. Fan Status

The **Fan Status** menu allows the user to view real-time fan statuses on the system.

TIME	DATE	UNIT##
Exh Fan 1: OFF		Speed
XXX°F		XXX%
*No Supply Airflow		
VFD Off-Line		
Fan in Balancing Mode		



#### ***THIS SCREEN IS AN EXAMPLE OF THE STATUS OF EXHAUST FAN #1***

The temperature on this screen displays real-time temperatures from the sensors linked to the exhaust fan. The speed on this screen displays the real-time speed of the exhaust fan.

If equipped with the airflow proving option, the fan has been turned on and supply airflow has not been detected, “No Supply Airflow” will be displayed.

If the exhaust fan is being controlled from a factory-provided VFD, but the VFD is not communicating back to the controller, “VFD: Off-Line” will be displayed.

If the exhaust fan has been turned on in the balancing menu, “Fan in Balancing Mode” will be displayed.

*Depending on the number of exhaust fans, navigate to other exhaust fan status pages by using the   buttons.*

TIME	DATE	UNIT##
Sup Fan 1: OFF		Speed
		XXX%
VFD Off-Line		
Fan in Balancing Mode		
Sup Fan is Tempering		



#### ***THIS SCREEN IS AN EXAMPLE OF THE STATUS OF SUPPLY FAN #1 - IF EQUIPPED***

The speed on this screen displays the real-time speed of the supply fan.

If the supply fan is being controlled from a factory provided VFD, but the VFD is not communicating back to the controller, “VFD: Off-Line” will be displayed.

If the supply fan has been turned on in the balancing menu, “Fan in Balancing Mode” will be displayed.

If the make-up air unit is currently heating/cooling the air, “Sup Fan is Tempering” will be displayed.

*Depending on the number of supply fans, navigate to other supply fan status pages by using the   buttons.*

## B. Clock

The **Clock** menu allows the user to view and alter the time and date. The user can also adjust the daylight savings time setting.

Clock	
Date:	MM/DD/YY
Hour:	15:30
Day:	Monday

### ***THE CLOCK SCREEN ALLOWS THE USER TO ADJUST THE TIME AND DATE.***

The time/date will not be adjustable on the controller if the user interface is the touch screen.

Clock	
DST:	Enable
Transition time:	60min
Start:	LAST SUNDAY
in MARCH	at 2.00
End:	LAST SUNDAY
in OCTOBER	at 3.00

### ***THIS SCREEN ALLOWS THE USER TO ADJUST DAYLIGHT SAVINGS TIME SETTING.***

The Daylight Savings time feature can be adjusted to meet the current daylight savings time requirements.

## C. Input/Output

The **Input/Output** menu allows the user to quickly view the status of the controller inputs and outputs.

Analog Input	
Temperature Sensor 1	
Input Ch: U1	
Value:	95.0°F

To manually control I/O values, go to the **Service menu > Service settings > I/O Manual Control**.

Similar screens appear for all controller inputs and outputs.

*Your controller may not utilize the input shown. See unit wiring diagram for your specific configuration.*

Digital Input	
Remote On/Off	
Input Ch: ID1	
Status:	Open

Similar screens appear for all controller inputs and outputs.

*Your controller may not utilize the input shown. See unit wiring diagram for your specific configuration.*

Relay Output	
Lights 1	
Output Ch: NO1	
Status:	OFF

Similar screens appear for all controller inputs and outputs.

*Your controller may not utilize the output shown. See unit wiring diagram for your specific configuration.*

Analog Output	
Exhaust Fan 1	
Output Ch: Y1	
Value:	5.00vdc

Similar screens appear for all controller inputs and outputs.

*Your controller may not utilize the output shown. See unit wiring diagram for your specific configuration.*



## D. Service

The **Service** menu allows the user to access several sub-menus regarding controller information, controller overrides, operating hours, BMS configuration, I/O manual management and Probe Adjustment. By accessing the **BMS Configuration** sub-menu, the user can adjust BMS protocol settings. (BACnet®, LonWorks®, Modbus)

### D. Service

#### a. System Information

The **System Information** sub-menu displays information about the controller and the program loaded on the controller.

#### Information

Greenheck Fan Corp.		
Code:		
Ver.: 2.00		04/13/17
Bios:	6.40	11/17/15
Boot:	5.02	09/30/13

**THIS SCREEN SHOWS VERSION, BOOT AND BIOS INFORMATION. BIOS AND BOOT PERTAIN TO THE CONTROLLER'S FIRMWARE AND OPERATING SYSTEM.**

### D. Service

#### b. VFD Status

The **VFD Status** sub-menu is for commissioning and troubleshooting. This sub-menu allows the user to view the Yaskawa VFD current status.

#### YASKAWA VFD Status

Exhaust VFD1	
Speed:	0.0Hz
Ref Frequency:	0.0Hz
Volts out:	0.0V
Rated Current:	0.0A
Amps out:	0.0A
Power out:	0.0kW

**THIS SCREEN ALLOWS THE USER TO VIEW THE CURRENT STATUS OF THE YASKAWA VFD. THERE WILL BE ADDITIONAL VFD SCREENS BASED ON THE NUMBER OF EXHAUST AND SUPPLY VFDs PROVIDED WITH THE SYSTEM.**

**Speed:** This is the actual speed of the Yaskawa VFD in Hertz.

**Ref Frequency:** This is the reference speed signal sent to it from the Vari-Flow controls.

**Volts out:** The voltage on the output side of the Yaskawa VFD .

**Rated Current:** This is the maximum rated current of the Yaskawa VFD.

**Amps out:** This is the current amperage that the Yaskawa VFD is providing to the motor.

**Power out:** This is the current power (kW) that the Yaskawa VFD is providing to the motor.

### D. Service

#### c. Setpoints

The **Setpoints** sub-menu allows the user to view and adjust temperature related parameters.

#### Temperature Interlock

Enable:	ON
Temp On:	115.0°F
Temp Off:	90.0°F
Delay Off:	600s

**THIS SCREEN DISPLAYS THE CURRENT SET POINTS FOR THE TEMPERATURE INTERLOCK FEATURE.**

The user can use the default exhaust fan temperature set points or configure them using the system optimization process. This option satisfies IMC. Fan(s) must automatically activate when cooking operations occur.

- **Temp On Set Point:** The temperature at which the fan(s) automatically turn on based on the temperature of the associated hood. The default is 115°F and is adjustable.
- **Temp Off Set Point:** The temperature at which the fan(s) automatically turn off based on the temperature of the associated hood. It must also satisfy the requirement of the Minimum Off Delay set point. The default is 90°F and is adjustable.
- **Off Delay Set Point:** The amount of time the temperature must remain below the Minimum Off set point before the fan(s) will turn off. The default is 10 minutes and is adjustable.

Exhaust 1 Setpoints		
	Temp	Speed
Low:	90.0°F	50.0%
High:	115.0°F	100.0%
Current Temp:	70.0°F	

**THIS SCREEN DISPLAYS EXHAUST FAN SETUP.**

**Low Temp:** Temperature that the fan will start to increase in speed from the low speed set point.

**High Temp:** Temperature that the fan will be at the high speed set point.

**Low Speed:** Minimum speed of the fan. (Not adjustable via this menu; see fan balancing).

**High Speed:** Maximum speed of the fan. (Not adjustable via this menu; see fan balancing).

*Depending on the number of exhaust fans, other exhaust fan setup pages will appear.*

High Temperature Alarm	
Enable:	Off
Temp On:	210.0°F
Temp Off:	205.0°F
Highest Temp:	70.0°F

**THIS SCREEN DISPLAYS THE HIGH TEMPERATURE ALARM SETTINGS.**

When enabled and the temperature reaches the Temp On set point, the shunt trip output will become active, forcing the electric equipment off. If there is an electric gas valve and it is wired into the VAV system, it will also turn that off. Once the temperature is below the Temp Off set point, the shunt trip output and gas valve will return to normal state.

Remember that the shunt trip breaker will have to be manually reset as well as the electric gas valve.

**D. Service**    
d. Fan Balancing

The **Fan Balancing** sub-menu allows the user to balance exhaust and supply fans easily.

Fan Balancing	
Exhaust Fan 1 Balance:	OFF
Minimum:	50.0
Maximum:	100.0

**THIS SCREEN ALLOWS THE USER TO BALANCE THE EXHAUST AND SUPPLY FANS.**

*There will be additional fans listed based on the number of exhaust and supply fans on this system.*

**Balance:** When it is in the OFF position, fans will work in normal operation. When set to *MAX* the fan will be forced to full speed. When set to *MIN* the fan will be forced to minimum speed.

**Minimum:** Based on the setting of *Balance*, the user can adjust the minimum speed to meet the requirements for the design of the system.

**Maximum:** Based on the setting of *Balance*, the user can adjust the maximum speed to meet the requirements for the design of the system.

**Make sure to return the mode of operation to OFF when balancing is complete. If the mode of operation is left in either MIN or MAX, the fan will not turn off.**

**D. Service**    
e. Wash Settings

Unless the panel is an Auto Scrubber Control Panel (ASCP), no wash setting pages will be visible. If information on these menus is needed, please reference the ASCP Control Panel Installation, Operation and Maintenance Manual which is available on our website, [greenheck.com](http://greenheck.com)

**D. Service**    
f. BMS Configuration

The **BMS Configuration** sub-menu allows the user to view and alter BMS protocol settings. If the BMS protocol is BACnet or Modbus, additional screens allow further configuration. See below for details. To access the **BMS Configuration** sub-menu, enter the service password (Default=1000).

BMS Configuration	
Protocol:	BACnet MSTP
BACnet Plugin?	YES

**THIS SCREEN ALLOWS THE USER TO SELECT THE BMS PROTOCOL. ALL BMS PROTOCOLS REQUIRE A COMMUNICATIONS CARD INSTALLED IN THE SERIAL CARD PORT, LOCATED ON THE FACE OF THE CONTROLLER.**

If the protocol is BACnet MSTP or BACnet IP/Eth, the user can change common BACnet parameters via the controller. The BACnet Plugin must be set to YES.



### MODBUS SETUP

Address: 1  
Baudrate 9600

### MSTP SETUP

Instance: 77000  
Baudrate 38400  
MAC Addr: 0  
MaxMasters: 127  
MaxInfoFrames: 20

### BACnet Read/Write

Function: Read  
Update? Yes

\*Cycle unit power to confirm write command.

### TCP/IP SETUP

Instance: 77000  
IP set by: DHCP  
IP: 128.2.104.134  
Subnet: 255.255.000.000  
Gateway: 128.2.0.12

### TCP/IP SETUP

DNS 1: 192.168.001.001  
DNS 2: 192.168.001.001  
Type: IP

### BACnet Read/Write

Function: Read  
Update? Yes

\*Cycle unit power to confirm write command.

### **THIS SCREEN ALLOWS THE USER TO ADJUST MODBUS PARAMETERS.**

*This screen only appears if the selected BMS protocol is set to Modbus.*

The address is the Modbus address of the card installed in the SERIAL CARD port located on the face of the controller. (Factory Default = 1).

The Baud Rate should be set to the BMS baud rate. (Factory Default = 9600).

### **THIS SCREEN ALLOWS THE USER TO ADJUST BACNET MSTP PARAMETERS.**

*This screen only appears if the selected BMS protocol is set to BACnet MSTP and BACnet Plugin = YES.*

If a BACnet MSTP card has been installed, the default parameters can be changed via the controller display. Factory settings are shown in the screen to the left.

#### To view current parameters:

1. Power on controller and allow several minutes to initialize.
2. Go to **BMS Configuration** menu and view BACnet Read/Write screen.
3. Change *Function* to *Read* and *Update?* to *YES*.

Current BACnet MSTP parameters should now be displayed in the BACnet MSTP SETUP screen. If all values appear to be zeros, consult the factory. (Make sure you have allowed several minutes for the controller to initialize).

*Values may appear to be zero prior to setting the Function to READ.*

#### To change BACnet MSTP parameters:

1. Power on controller and allow several minutes to initialize.
2. Go to **BMS Configuration** menu and view MSTP SETUP screen.
3. Move cursor to desired parameter by pressing the  $\uparrow\downarrow$  buttons. Press  $\leftarrow$  to select the parameter to change. Press the  $\uparrow\downarrow$  buttons to adjust the parameter. Press  $\leftarrow$  to save adjusted value.
4. Once desired parameters have been entered, go to BACnet Read/Write screen. Change *Function* to *Write* and *Update?* to *YES*.
5. Reboot the controller by cycling power to the unit. Allow several minutes for the controller to initialize.
6. View MSTP parameters. If changed values did not save, contact the factory.

### **THIS SCREEN ALLOWS THE USER TO ADJUST BACNET IP PARAMETERS.**

*This screen only appears if the selected BMS protocol is set to BACnet IP/Eth and BACnet Plugin = YES.*

If a BACnet IP card has been installed, the default parameters can be changed via the controller display. **The card is in DHCP mode from the factory.** Once communication is established, the user can enter static IP parameters.

#### To view current parameters:

1. Power on controller and allow several minutes to initialize.
2. Go to **BMS Configuration** menu and view BACnet Read/Write screen.
3. Change *Function* to *Read* and *Update?* to *YES*.

Current BACnet IP parameters should now be displayed in the BACnet TCP/IP SETUP screen. If all values appear to be zeros, consult the factory. (Make sure you have allowed several minutes for the controller to initialize).

*\*Values may appear to be zero prior to setting the Function to READ.*

#### To change BACnet TCP/IP parameters:

1. Power on the controller and allow several minutes to initialize.
2. Go to **BMS Configuration** menu and view TCP/IP SETUP screen.
3. Move cursor to desired parameter by pressing the  $\uparrow\downarrow$  buttons. Press  $\leftarrow$  to select the parameter to change. Press the  $\uparrow\downarrow$  buttons to adjust the parameter. Press  $\leftarrow$  to save adjusted value.
4. Once desired parameters have been entered, go to BACnet Read/Write screen. Change *Function* to *Write* and *Update?* to *YES*.
5. Reboot the controller by cycling power to the unit. Allow several minutes for the controller to initialize.
6. View TCP/IP parameters. If changed values did not save, contact the factory.

<b>D. Service</b>	
g. Service Settings	
a. Fan Operation	
b. I/O Manual Control	
c. Hood Manual Control	
d. Light Manual Control	
e. Wash Manual Control	
f. Sensor Calibration	
g. User Save/Restore	
h. Alarm History Reset	

<b>D. Service</b>	
g. Service Settings	
a. Fan Operation	

<b>Full Speed Settings</b>	
Full Speed Override	
Duration:	10min
Full Speed Status:	OFF

<b>Kitchen Fire Settings</b>	
Exhaust fan operation during fire:	
Fans On - Full Speed	
Supply fan operation during fire:	
Fans Off	

<b>Exhaust Fan Operation</b>	
Minimum On	1s
Minimum Off	1s

<b>Supply Fan Operation</b>	
Supply Fan Airflow	
Proving Delay:	15s

<b>Supply Fan Operation</b>	
Minimum Tempering Setpoints	
Supply Fan 1:	66.0%
Supply Fan 2:	66.0%
Supply Fan 3:	66.0%
Supply Fan 4:	66.0%

The **Service Settings** sub-menu allows the user to adjust fan operation, manually enable/disable inputs and outputs, hoods, and lights, calibrate sensors, create or restore user settings, and reset the alarm history log.

In **Fan Operation**, the user will be able to adjust full speed override settings, kitchen fire settings and exhaust/supply fan operation settings.

**THIS SCREEN ALLOWS THE USER TO ADJUST THE FAN OVERRIDE/FAN 100% SETTINGS.**

**Full Speed Override Duration:** When the fans are running and the full speed override button is pressed, the fans will ramp up to full speed for this time limit. Once this time limit is reached, the fans will return to a speed based on hood temperature.

**Full Speed Status:** This will display whether the fans are in full speed mode. (ON = full speed button has been pressed, OFF = normal fan operation).

**THIS SCREEN ALLOWS THE USER TO ADJUST THE KITCHEN FIRE SETTINGS.**

**Exhaust fan operation during fire:** During a kitchen fire, this will determine exhaust fan operation. (Default will be Fans On - Full Speed)

**Supply fan operation during fire:** During a kitchen fire, this will determine supply fan operation. (Default will be Fans Off). This will only be visible/adjustable **IF** there is at least one supply fan controlled by the Vari-Flow system.

**NOTE: Do not adjust these settings after a fire test has been completed.**

**THIS SCREEN ALLOWS THE USER TO ADJUST MINIMUM ON/MINIMUM OFF TIME FOR EXHAUST FANS.**

**Minimum On:** This prevents all exhaust fans from shutting off for the maximum time selected. (Factory Default = 1 second)

**Minimum Off:** This prevents all exhaust fans from turning on for the minimum time selected. (Factory Default = 1 second)

**THIS SCREEN ALLOWS THE USER TO ADJUST THE SUPPLY FAN AIRFLOW PROVING DELAY**

This screen will only be visible if the Vari-Flow is controlling at least one supply fan and is configured for Airflow Proving.

**Supply Fan Airflow Proving Delay:** This will delay the time for the Vari-Flow to allow for the supply fan to prove before logging a supply fan proving alarm. (Factory Default = 15 seconds)

**WHEN A SUPPLY FAN IS ON AND TEMPERING, SETTINGS ON THIS SCREEN WILL PREVENT THE FANS FROM FALLING BELOW A SPECIFIC SPEED**

This screen will only be visible if the Vari-Flow is controlling at least one supply fan. Factory default minimum tempering speeds are 66.0%.



### Supply Fan Operation

Pressure Setpoints  
Setpoint: 0.000iwc  
Pressure: 0.000iwc

### Supply Fan Operation

Modulating Setup  
Band: 50.0  
Integration Time: 180s  
Derivative Time: 12s  
Dead Band OFF  
Above Set Point 1.0  
Below Set Point 1.0

## D. Service

g. Service Settings

b. I/O Manual Control

### Analog Input

Temperature Sensor 1  
Input Ch: U1  
Manual Control: OFF  
Manual Value: 0  
Value: 70.0°F

### Digital Input

Remote On/Off  
Input Ch: ID1  
Manual Control: OFF  
Manual Position: CLOSED  
Status: Open

### Relay Output

Lights 1  
Output Ch: NO1  
Manual Control: OFF  
Manual Position: OFF  
Status: ON

### Analog Output

Exhaust Fan 1  
Output Ch: Y1  
Manual Control: OFF  
Manual Value: 0.00vdc  
Value: 5.00vdc

**WHEN ONE SUPPLY FAN SPEED IS CONTROLLED VIA STATIC PRESSURE, THESE SETTINGS WILL BE VISIBLE AND ADJUSTABLE.**

Supply fan speed can be controlled via a pressure differential between two spaces. Pressure setpoints and different PID loop settings can be adjusted with this option. It is recommended to contact the factory for assistance before adjusting these settings.

In **I/O Manual Control**, the user will be able to manually adjust inputs/outputs.

**NOTE:** The manual adjustment of these input and/or outputs should only be adjusted in the event of troubleshooting. We suggest these parameters only be changed with the advice of factory personnel.

**Manual Control:** Allows the user to override the analog input for troubleshooting.

**Manual Value:** The value to force the input to when in an override state.

**Value:** The current value of the analog input.

*Similar screens appear for all additional controller analog inputs.*

**Manual Control:** Allows the user to override the digital input for troubleshooting.

**Manual Position:** The value to force the input to when in an override state.

**Status:** The current state of the digital input.

*Similar screens appear for all additional controller digital inputs.*

**Manual Control:** Allows the user to override the digital input for troubleshooting.

**Manual Position:** The value to force the output to when in an override state.

**Status:** The current state of the relay output.

*Similar screens appear for all additional controller relay outputs.*

**Manual Control:** Allows the user to override the analog output for troubleshooting.

**Manual Value:** The value to force the input to when in an override state.

**Value:** The current value of the analog output.

*Similar screens appear for all additional controller analog inputs.*

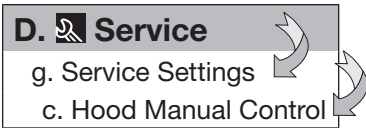

In **Hood Manual Control**, the user will be able to manually turn on/off individual hood systems (turn on/off individual fans).

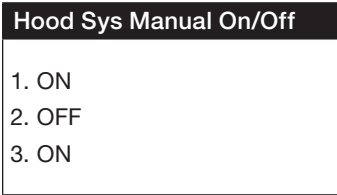

*Depending on how many hood systems there are, the user may see less/more hoods that can be controlled.*

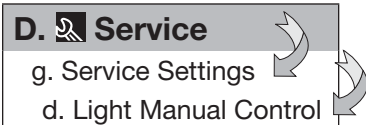

In **Light Manual Control**, the user will be able to manually turn on/off individual light circuits.

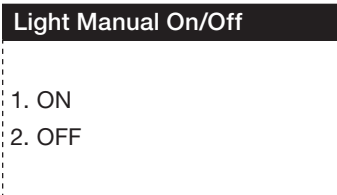

*Depending on how many light circuits were configured on the system, the user may see less/more lights that can be controlled.*

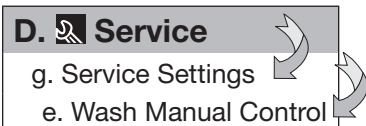

Unless the panel is an Auto Scrubber Control Panel (ASCP), no manual wash control pages will be visible in the **Wash Manual Control** sub-menu as there are no hoods to wash. If information on these menus is needed, reference the ASCP Control Panel Installation, Operation and Maintenance Manual available on [greenheck.com](http://greenheck.com)

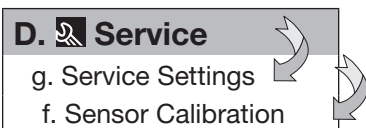

In **Sensor Calibration**, the user will be able to create temperature offsets for hood sensors and/or static pressure supply sensors, *if equipped*.

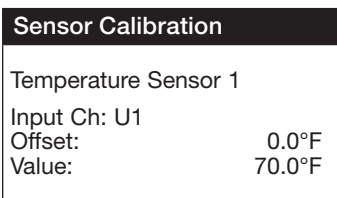

**Offset:** This adjustable value can be used to calibrate the sensor with an offset value. (Factory Default = 0.0°F)

**Value:** This is the current value of the probe. (offset adjustment is added).

*Similar screens are available for the remaining probes and static pressure sensor, if equipped.*

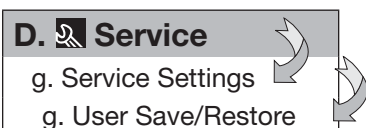

In **User Save/Restore**, the user will be able to save and restore the default parameters stored in memory.



If the user would like to save their settings, move the cursor to the SAVE position and change to ON. This will save all of the current parameters into memory as Service Settings. If the user would like to restore to these values at some point in the future, moving the cursor to the RESTORE position and selecting ON, will restore the controller to the user saved defaults.



## D. Service

g. Service Settings

h. Alarm History Reset

### Alarm History Reset

This will clear the Alarm history.

Continue? OFF

In **Alarm History Reset**, the user will be able reset the alarm history log.

---

**THIS SCREEN ALLOWS THE USER TO CLEAR THE ALARM FROM MEMORY.**

---

If the user would like to clear the alarm log, move the cursor to the OFF position and change to ON.

## E. Manufacturer

The **Manufacturer** menu allows the user to access several sub-menus regarding controller configuration, I/O configuration, factory settings, controller initialization pages, and factory save/restore pages. These changes are to be completed under factory advisement only!

### E. Manufacturer

a. Configuration

The **Configuration** sub-menu allows the user to adjust an assortment of items including units (temperature), clock mode (12hr or 24hr), buzzer enable/disable, and allows for modifying passwords. However, these changes are to be completed under factory advisement only!

### Configuration

Unit Address:	1
Temperature Units:	°F
Force Clock Enable:	OFF
Clock Mode:	12h
Disable Buzzer:	ON
Startup Delay:	5s

---

**THIS SCREEN DISPLAYS AND ALLOWS ADJUSTMENT OF THE UNIT SETTINGS.**

---

**Unit Address:** This is a reference to the unit address of the controller. It cannot be adjusted here.

**Temperature Units:** The temperature units can be adjusted between Celsius and Fahrenheit.

**Force Clock Enable:** This provides the ability to enable a clock for the controller without clock device on board. This should remain set at OFF.

**Clock Mode:** 12 hour or 24 hour.

**Disable Buzzer:** When turned to ON, the on-board buzzer is disabled. (Buzzer will still sound when gas is reset if the system was configured with the gas reset option).

**Startup Delay:** This is the time delay added at start-up. This should remain set at 5 seconds.

### Configuration

Backlight Timer:	300s
------------------	------

---

**THIS SCREEN DISPLAYS AND ALLOWS ADJUSTMENT OF THE BACKLIGHT TIMER (FACTORY DEFAULT = 300 SECONDS)**

---

### Configuration

Analog Input Filtering	
Enable:	OFF
Input 1:	19s
Input 2:	19s
Input 3:	19s
Input 4:	19s
Input 5:	19s

---

**THIS SCREEN DISPLAYS AND ALLOWS ADJUSTMENT OF ANALOG INPUT FILTERING**

---

*Similar screens appear for all additional controller analog inputs.*

### Configuration

Manual Control Reset

Enable:	OFF
Time:	0min

---

**THIS SCREEN PROVIDES A MEANS TO RESET MANUAL I/O.**

---

Changing the Enable parameter to ON will reset all of the manual I/O settings after the time (Factory Default = 0 minutes expires).

## Configuration

Modbus Settings (VFDs)  
Port: FieldBus 2  
BaudRate: 19200  
Data: 8, None, 2

## Modulating Setup

Supply Fan  
Cntrl: REV PID  
Band: 50  
Integration Time: 180s  
Derivative Time: 12s  
Min: -1000 Max: 0  
Output Period: 500ms

## Passwords



Insert new passwords  
Service (PW1): 0000  
Manufacturer (PW2): 0000

## E. Manufacturer

### b. I/O Configuration

## Analog Input

Temp Sensor 1  
En: ON Ch: U1  
Normal PT1000  
Offset: 0.0°F  
Value: 70.0°F

## Analog Input

Temp Sensor 2  
Out of Range Alarm  
Power Delay: 15s  
Run Delay: 15s

## Digital Input

Remote On/Off  
Enable: ON  
Channel: ID1  
Action: OPEN  
Delay: 0s  
Status: Open

## Relay Output

Lights 1  
Enable: ON  
Channel: NO1  
Status: OFF

## **THIS SCREEN DISPLAYS THE VFD MODBUS SETTINGS**

This screen will only be visible if at least one Modbus VFD is controlled by the controller.

## **THIS SCREEN DISPLAYS THE STATIC PRESSURE CONTROL SETTINGS.**

This screen will only be visible if one supply fan is configured on the system and the supply fan speed is controlled via static pressure.

## **THIS SCREEN ALLOWS THE USER TO CHANGE THE SERVICE (PW1) AND MANUFACTURER PASSWORD (PW2).**

This default service (PW1) password is 1000.

The **I/O Configuration** sub-menu allows adjustment of all controller inputs and outputs. These screens are available to provide further information and allow for more adjustments on all inputs and outputs on the controller. However, these changes are to be done under factory advisement only!

*These are examples of analog input screens. Similar screens appear for all additional controller analog inputs used.*

*This is an example of a digital output screen. Similar screens appear for all additional controller digital inputs used.*

*This is an example of a relay output screen. Similar screens appear for all additional controller relay outputs used.*



Analog Output	
Exhaust Fan 1	
Enable:	ON
Channel:	Y1
Action:	DIRECT
Minimum:	0.00vdc
Maximum:	10.00vdc
Value:	0.00vdc

*This is an example of an analog output screen. Similar screens appear for all additional controller analog outputs used.*

**E. Manufacturer**  
c. Factory Settings

The **Factory Settings** sub-menu allows adjustments to the overall system setup. Adjusting any of these settings will affect basic functions of the controller. Upon adjusting any of these settings, the controller power should be cycled. Changes are to be done under factory advisement only!

Factory Settings 1	
Brand:	GREENHECK
System Selection:	S
Interface:	KEYPAD
Hoods:	1
Sumps:	0
Exhaust Fans:	1

*This is an example of the first factory settings screen. Additional screens will be accessible.*

**E. Manufacturer**  
d. Initialization

The **Initialization** sub-menu allows the user to reinitialize the controller. Reinitializing the controller will result in a non-customized controller and is to be done under factory advisement only!

Initialization	
DEFAULT INSTALLATION	
Erase user settings and install global default values:	NO

*Shown here is the default installation screen. To initialize, move the cursor to NO using the enter button, press the up bottom to change to YES, and press the enter button.*

**E. Manufacturer**  
e. Factory Save/Restore

The **Factory Save/Restore** sub-menu allows the user to save or restore the factory parameters. This is to be done under factory advisement only!

Factory Save/Restore	
	
Save?	OFF
Restore?	OFF
Auto Restore?	No

**THIS SCREEN ALLOWS THE USER TO SAVE AND RESTORE THE FACTORY DEFAULT PARAMETERS STORED IN MEMORY.**

The Factory Settings include the Factory default parameters and the unit setup code. If the user would like to restore to these parameters, move the cursor to the Restore position and change to ON.

Factory Delete	
	
CLEAR ALL SAVED DATA FACTORY+USER:	OFF

**THIS SCREEN ALLOWS THE USER TO CLEAR ALL SAVED DATA.**

## Keypad Navigation

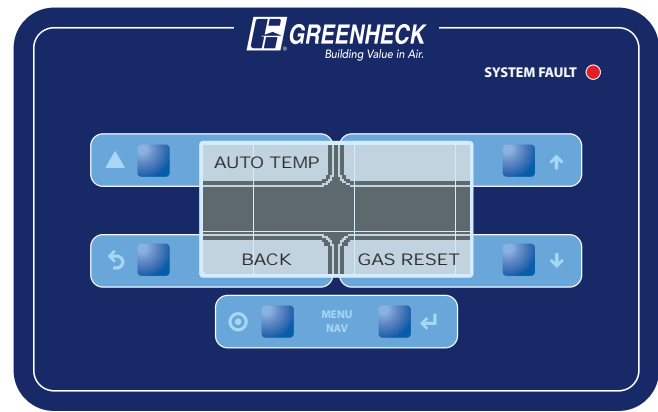
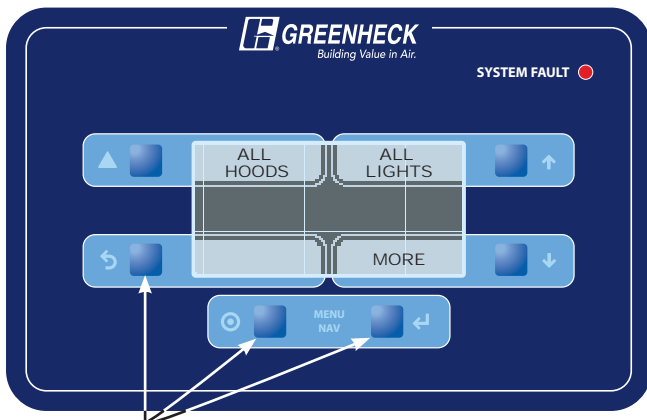

When '**BUTTON(S)**' are mentioned in the description below, we are referring to the 'squares' on the keypad. The following information details the Daily Operations of the Vari-Flow System keypad buttons and their functions.

**HOODS/ALL HOODS** - Momentarily pressing the 'ALL HOODS' button will turn on all hoods (fans) associated with the system. If all of the hoods (fans) are on, the background behind 'ALL HOODS' text will be dark. Pressing the same button again will turn off all hoods. If 'HOODS' is displayed instead of 'ALL HOODS', individual hood system control is available. Pressing the 'HOODS' button accesses another screen where individual hoods (fans) can be turned on and off. Press the button next to each hood system identified to enable/disable that hood/fan. Press the 'MORE' button (if applicable) to access additional hood systems. Press the 'BACK' button to return to the previous screen.

**ALL LIGHTS/LIGHTS** - Momentarily pressing the 'ALL LIGHTS' button will activate all the lights for hoods associated with the system. If all hood lights are on, the background behind the 'ALL LIGHTS' text will be dark. Pressing the button again turns off the lights for all hoods. If 'LIGHTS' is displayed instead of 'ALL LIGHTS', individual light control is available. Pressing 'LIGHTS' button will access another screen where individual light circuits can be turned on and off. Press the light button next to each light circuit identified to enable/disable the lights for the hood(s). Press the 'MORE' button (if applicable) to access additional hood light circuits. Press the 'BACK' button to return to the previous screen.

**MORE, if equipped** - Momentarily pressing the 'MORE' button will navigate to an additional screen where the user will be able to enable/disable heating or cooling on the make-up air unit (if equipped with the auto tempering option) and/or reset the gas valve (if equipped with gas reset option).

**BACK, if equipped** - Momentarily pressing 'BACK' button will navigate to the previous screen.

**AUTO TEMP, if equipped** - Momentarily pressing the 'AUTO TEMP' button will enable the make-up air unit to heat and cool the air based on heating/cooling inlet air sensors. If auto tempering is on, the background behind 'AUTO TEMP' will be dark. Pressing the same button again will turn off auto tempering and therefore prevent

your make-up air unit from heating/cooling the air.

**GAS RESET, if equipped** - Momentarily pressing the 'GAS RESET' button will turn open the electric gas valve and allow gas to flow to the appliance(s). If the gas valve is on, the background behind the 'GAS RESET' text will be dark. Once this is turned on, the gas reset will be permanently enabled. Only when a high temperature alarm or a kitchen fire is detected will close the gas valve again.

### NOTE

Immediately after resetting gas valve, make sure relight all standing pilot lights to prevent gas from flowing into the kitchen. As a reminder, the controller will beep three times upon resetting the value.

### Display functionality and control:

To change the display contrast, hold the buttons next to the Alarm ⚠ and Program Ⓞ icons simultaneously while pressing the buttons next to the ↓ and ↑ arrows. The down arrow will make the screen lighter and the up arrow will make the screen darker.

Upon any alarm, the 'SYSTEM FAULT' red LED light on the face of the keypad starts flashing. Once all alarms are corrected, this LED will stop flashing and no longer be illuminated.

Through the middle of the screen, system status messages will be displayed as a reference. These system statuses will include:

- Current alarms
- Time remaining on fan 100% override timer (if on)
- Hoods that are on by temperature interlock
- Hoods that are on by the user interface
- Lights that are on by the user interface
- Fans that are in balancing mode

The keypad also includes indicators next to buttons that correspond to help the buttons on the controller. These can be used to navigate through the controller using the keypad. To access the main menu, simply press and hold the button next to the Program Ⓞ icon for **five seconds** or until the screen changes to the main menu.

# Touch Screen Navigation



**Momentarily press or tap to access the menu or enable or disable the action of the associated icon. All icons surrounded by blue are momentarily push buttons.**



**ALL LIGHTS ON/OFF** (if equipped) - turns on all hood lights associated with the system. When all hood lights are activated, the light bulbs within the icon illuminate.

Tapping the icon again will turn off the lights.



**INDIVIDUAL LIGHT ON/OFF** - access a secondary screen menu whereby control over individual light circuits is available. Tap the icon next to each light circuit identified to enable/disable. Press the back arrow to return to the home screen.



**ALL HOODS ON/OFF** - turns on all hoods (fans) associated with the system. If all hoods are operating, the fan propellers in the icon starts spinning. Press again to turn off all hoods.

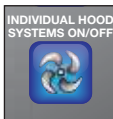

**INDIVIDUAL HOOD SYSTEMS ON/OFF** (if equipped) - allows control over multiple fans that are not tied to the same hood. Access to a secondary menu screen allowing the



ability to enable/disable individual hood systems. Press the back arrow to return to the home screen.



**100% OVERRIDE ON/OFF** (if equipped) - forces the fans that are currently operating to full speed. (This icon will only be visible if at least one exhaust fan is running).

When turned on, the third bar on the icon blinks green. Fans will return to the speed determined by the hood temperature after the timer has expired (default time is 10 minutes). Pressing this icon when 100% OVERRIDE is on, will also return the fans to the speed determined by the hood temperature.



**AUTO TEMPERING ON/OFF** (if equipped) - enables the make-up air unit to automatically heat and/or cool the air based on the inlet air temperature. When auto tempering is enabled, the thermometer illuminates. Pressing the icon again disables auto tempering, the make-up air unit's heat and/or cooling capabilities.



**GAS RESET ON/OFF** (if equipped) - turns on the gas to the appliance(s); opens the electric gas valve. The gas valve will close (gas will be shut off) if a fire occurs or high temperature is detected in any hood. When the gas is on, the icon will show 'ON'.

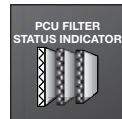

**PCU FILTER STATUS** (if equipped) - indicates loaded/clogged filter(s) in the Pollution Control Unit (PCU). If filters are satisfactory, filter image will remain gray. The image of the affected filter(s) will flash red. Once clogged, the filter(s) must be replaced.

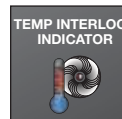

**TEMP INTERLOCK INDICATOR** - indicates if at least one hood is operating in temperature mode. If the fan(s) were not turned on via the ALL HOODS ON/OFF or INDIVIDUAL HOOD SYSTEMS ON/OFF and the temperature in the hood is above the temperature interlock setpoint, this icon will animate. The fan(s) will continue to operate until the temperature is below the set point for the amount of time in the temperature interlock settings.

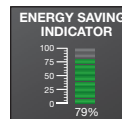

**ENERGY SAVINGS INDICATOR** - this appears if at least one fan is operating. Displays real-time electrical energy savings due to reducing fan speeds.

## NOTE

This percentage does not take into consideration additional savings from lowering the airflow requirements for tempered make-up air and building HVAC air.



**HELP** - this will display a help menu and navigation tips.



**NAVIGATION BAR** (arrow at bottom of the screen) - pulls up the hidden NAVIGATION menu allowing access to alarms, home, and settings/configuration/information screens. This is available on every screen.



The alarm icon directs you to the alarms screen. **This icon will illuminate red and blink when an alarm has been triggered.**

The middle icon directs you to the home screen.

The icon on the far right allows navigation to the settings/configuration/information menu screen.

Pressing either of the black arrows to the right and left of these three buttons will hide the navigation menu bar.

### Service Password Screen

#### NOTE

The Service Password must be entered to access the SETTINGS, CONFIGURATION and INFORMATION screen. The default service password is 1000.

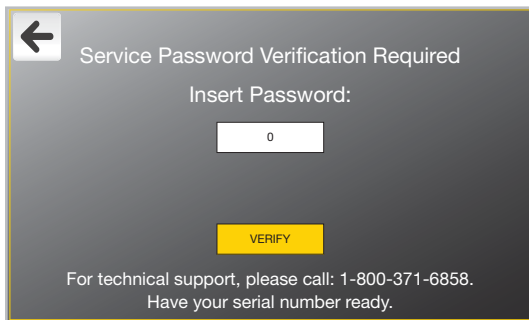

### Active Alarms Example

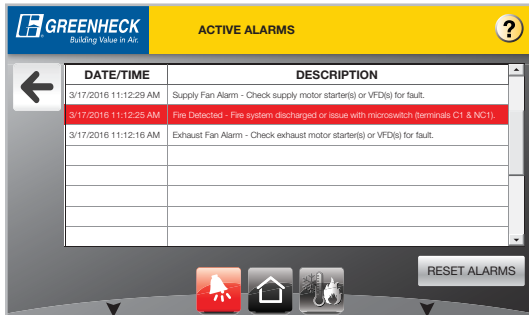

## General Information

Any field surrounded by a box with a white fill indicates that it is editable.

If an editable field displays a numerical value and the user taps the field, a number keypad will display. After entering the desired value, press the Enter button.

If the editable field is an alphanumeric value, a standard keyboard will display. After entering the desired value, press the Enter button.

The field may also display a multiple choice ON/OFF, or a checkmark box. For the ON/OFF fields, press the box opposite of the checked box to change the option from either OFF to ON or visa versa. For checkmark boxes, to unlink an item momentarily press on the box to remove the checkmark or conversely, to link an item, press the box to add a checkmark.

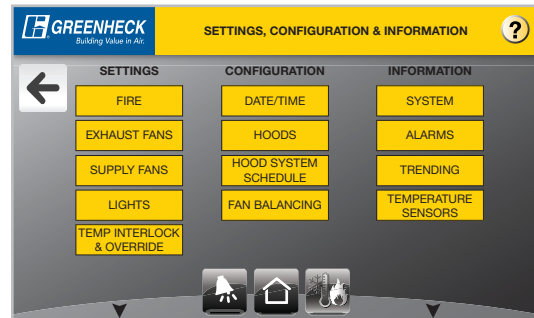

## Settings

### • Fire

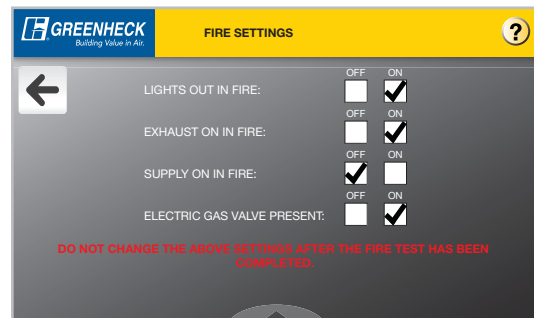

**Lights Out in Fire:** Changing this setting to ON will turn all hood lights off during a fire.

**Exhaust On in Fire:** Changing this setting to ON will turn all exhaust fans controlled by the system to full speed during a fire.

**Supply On in Fire:** Changing this setting to ON will turn all supply fans controlled by the system to full speed during a fire.

**Electric Gas Valve Present:** Changing this setting to ON will enable the gas reset option; provides a means of manually resetting an electric gas valve.

## Settings - continued

### • Exhaust Fans

**Fan Name:** User can adjust the “nickname” of the fan to something such as “FRYER FAN”.

**Design CFM:** Set from factory (full speed, exhaust airflow rate).

**Current CFM:** Current CFM exhausted from the fan.

**Low Temp Setpoint:** Temperature at or below this setpoint will cause the fan to run at the low speed.

**High Temp Setpoint:** Temperature at or above this setpoint will cause the fan to run at the high speed.

**Low Speed:** Lowest fan operational speed.

**Highest Speed:** Highest fan operational speed.

### NOTE

The fans will modulate speed when the temperature is between the low and high temp setpoints.

### • Supply Fans

**Fan Name:** User can adjust the “nickname” of the fan to something such as “HOOD1 SUPPLY”.

**Design CFM:** Set from factory (full speed, supply airflow rate).

**Current CFM:** Current CFM supplied from the fan.

**Low Speed:** Lowest fan operational speed.

**Highest Speed:** Highest fan operational speed.

### • Lights

**Light Circuit Name:** User can adjust the nickname of each light circuit.

### • Temperature Interlock & Override

**Temperature Interlock Enabled:** User can enable or disable temperature interlock.

### WARNING

Temperature interlock (2015 IMC Section 507.1.1) is a requirement in most jurisdictions. DO NOT DISABLE THIS OPTION UNLESS INSTRUCTED BY THE FACTORY OR AUTHORITY HAVING JURISDICTION. DO NOT CHANGE THIS SETTING ONCE THE SYSTEM HAS PASSED INSPECTION.

**Temperature On Setpoint:** The temperature at which the fan(s), if off, will automatically turn on.

**Temperature Off Setpoint:** Temperature at which the fan(s) will turn off once the time delay setpoint is reached - assuming the fan(s) have not been turned on manually by the touch screen.

**Time Delay Off Setpoint:** Amount of time the fan(s) need to be below the temperature off setpoint before the fan(s) will shut off.

**100% Override Button Timer:** Amount of time the fans are at full speed when the 100% override button is pressed.

## Configuration

### • Date / Time

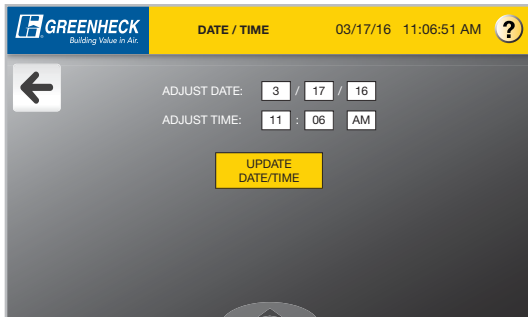

**Adjust Date:** Adjust the date. DD/MM/YY format.

**Adjust Time:** Adjust the time.

To store the adjusted date and time in both the touch screen and the main controller, press 'UPDATE DATE/TIME'.

### • Hoods

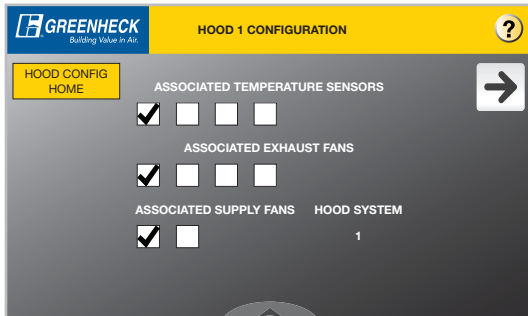

**Associated Temperature Sensors:** Link sensors to the hood by checking or unchecking the boxes.

**Associated Exhaust Fans:** Link exhaust fans to the hood by checking or unchecking the boxes.

**Associated Supply Fans:** Link supply fans to the hood by checking or unchecking the boxes.

**Hood System:** Based on the selections on the screen, this provides the hood system that the hood currently is linked to.

### • Hood System Scheduling

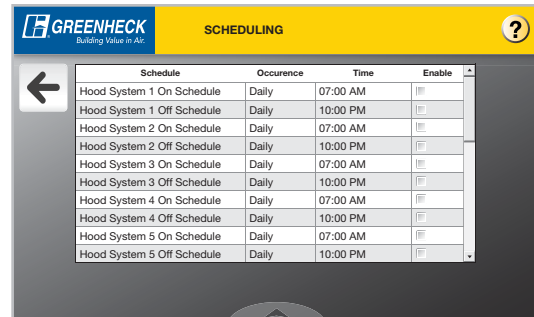

Allows the user to set up a scheduled time each hood system should turn on/off during the day. Can adjust the occurrence, time on and time off. In order for the scheduling to be used, the Enable check box must be selected.

### • Fan Balancing

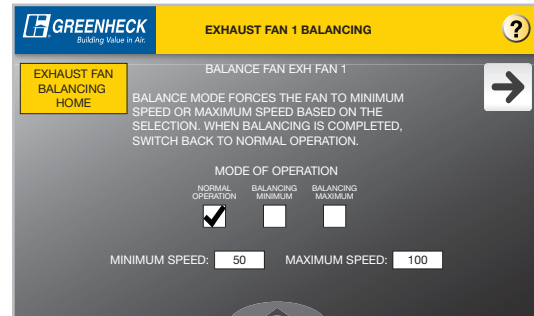

Balancing allows the user to easily balance the exhaust and supply fans.

#### **Mode of Operation: Normal Operation**

Fans operate based off the fans on/off buttons and temperatures.

#### **Mode of Operation: Balance Minimum**

Forces the fans on and at the speed shown in the minimum speed box.

#### **Mode of Operation: Balance Maximum**

Forces the fans on and at the speed shown in the maximum speed box.

**Minimum Speed:** Adjust the minimum speed as necessary for the design of the system.

**Maximum Speed:** Adjust the maximum fan speed as necessary for the design of the system.

### NOTE

Make sure to return the mode of operation to 'NORMAL OPERATION' when balancing is complete. If the mode of operation is left in Balance Minimum or Balancing Maximum, the fan(s) will not turn off.

## Information

### • System Information



Displays important system information including firmware and software versions.

### • Temperature Sensors

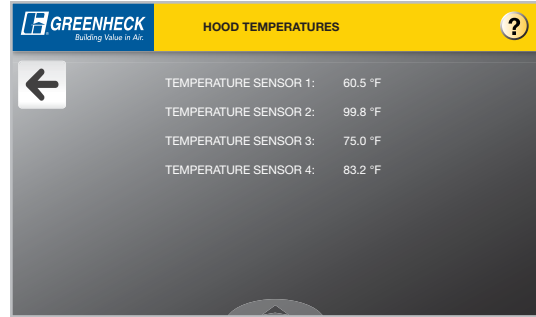

All current sensor temperatures are shown on this information screen.

### • Alarms

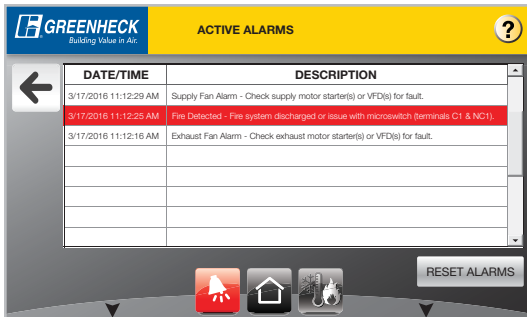

Alarms will show all current alarms. In the event of an alarm, the alarm page will automatically be displayed. The alarm description, date and time will be displayed for each current fault. If no faults exist, 'No Active Alarms' will be displayed. Once a fault is corrected, it will automatically be cleared.

### • Trending

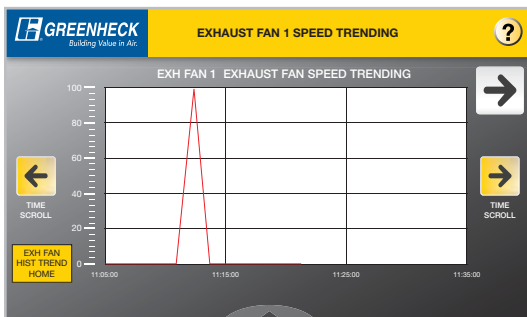

Trending provides additional information that shows history trending for exhaust fans, supply fans and temperature sensors. Scrolling forward or backward in time can be done using the orange colored arrow buttons.

## Troubleshooting

### **Problem:** Smoke spilling out of hoods at 100% operation.

Maximum fan speed has been scaled down from 100%	Increase exhaust fan maximum speed to 100%. Refer to information provided on page 18 to adjust setpoints.
Improper hood design	Check hood overhang, cross drafts or proper make-up air

### **Problem:** Smoke spilling out of hood(s) at lowest speeds

Fan minimum speed is set too low	Increase exhaust fan minimum speeds. Refer to information provided on page 18 to adjust setpoints.
Improper hood design	Check hood overhang, cross drafts or proper make-up air

### **Problem:** Fans do not turn up to maximum speed

Dirty temperature sensor	Clean grease from temperature sensor
High temperature set point is set too high	Decrease the high temperature set point (115°F default). Refer to information provided on page 18 to adjust setpoints.
Fans are in balancing mode	Check balancing menus to determine if fans are in balancing mode. Refer to information provided on page 18 to adjust setpoints.
Fan 100% button is activated	Check 100% timer setting

### **Problem:** Fans do not turn down to minimum speed

Dirty temperature sensor	Clean grease from temperature sensor
Low temperature set point is set too low	Increase the low temperature set point (90°F default)
Fans are in balancing mode	Check balancing menus to determine if fans are in balancing mode

### **Problem:** Exhaust fan on and supply fan off

Broken supply fan belt	Replace fan belt
Fire fault	Check fire suppression microswitch connection
Exhaust fan VFD in local control	Put exhaust fan VFD back into remote control
Supply fan breaker tripped	Reset breaker

### **Problem:** Supply fan on and exhaust fan off

Broken exhaust fan belt	Replace fan belt
Supply fan VFD in local control	Put supply fan VFD back into remote control
Exhaust fan breaker tripped	Reset breaker

### **Problem:** Fan wheel rotates in wrong direction

VFD output wiring incorrect	Switch any two leads on the hood side of the VFD to the fan motor <b>OR</b> change PAR b1-14 from 00 to 01 on the VFD
-----------------------------	---

### **Problem:** 100% override does not increase exhaust speed

Exhaust already at 100% due to hood temperature	Proper operation
---	------------------

### **Problem:** Fan button is on, but fans do not turn on

Broken fan belt	Replace fan belt
VFD fault	Check VFD for faults

### **Problem:** Fan button is off, but the fans will not turn off

Vari-Flow is operating in temperature interlock mode. Temperature interlock indicator on keypad or touch screen will be on.	The temperature in the hood is still above the temperature interlock off set point. It will automatically turn off once below the setpoint and off delay time has expired.
---	--

### **Problem:** Hood light(s) button on, but actual lights are not on

Light bulbs are burned out	Replace hood light bulbs
Bad wiring connection	Verify lights are wired to the correct terminals. Refer to the lights wiring instructions on page 5



# Troubleshooting

<b>Problem:</b> Fans do not turn on automatically	
Temperature interlock is disabled	Enable the temperature interlock option (default is enabled) in the set point menu
Interlock set point set too high	Decrease the temperature interlock on set point
<b>Problem:</b> Pressure sensor alarm	
Kinked hose	Remove kink or replace hose
Controlled space not holding pressure	Adjust the static pressure set point or change supply mode
<b>Problem:</b> Kitchen fire alarm	
Kitchen fire is in progress; fire suppression has dumped	Evacuate the facility immediately and contact your local fire department.
Fire system microswitch is in the fire position	Check the fire suppression microswitch connections
<b>Problem:</b> Temperature sensor input failure	
Faulty wiring to temperature sensor	Check wiring at Vari-Flow control panel and at hood connection
Incorrect programming	Check the temperature sensor settings (consult factory)
Dirty/Faulty sensor	Clean or replace sensor
<b>Problem:</b> Exhaust / supply VFD fault - general	
Look at the VFD for fault identification	Refer to the Yaskawa Quick Start Guide for fault and tips to correct. Once corrected, recycle power to the VFD via the breaker. Wait until all power is drained from the VFD before turning power back on.
<b>Problem:</b> Exhaust / supply VFD fault. Fault code “CE” or “CALL”	
Faulty communication wiring between VFD and controller	Check all communication wiring between VFD and the Vari-Flow controller. Confirm all wiring corresponds with factory wiring diagram.
Incorrect programming in VFD	Check VFD communication parameters
Incorrect programming in Vari-Flow controller	Check Vari-Flow controller factory settings pages (consult factory)
<b>Problem:</b> Fan is making grinding/winding noise and/or appears to struggle to operate	
Carrier frequency on VFD needs adjustment	Change parameter C6-02 on the VFD anywhere between values 01 and 06, testing the fan at maximum speed with each adjustment. Set this parameter at whichever value corrects this issue.
Issue with fan bearings/drive components	Check fan bearings and fan drive components. Replace if necessary.
<b>Problem:</b> Keypad connected via factory-supplied RJ25 cable to J10 port on main controller, but keypad displays a blank screen	
Vari-Flow controller/panel is off	Turn panel on
Contrast on keypad has been adjusted	Press and hold top left button and top middle hidden button on the keypad overlay. While holding these buttons down, repeatedly press the bottom left button (makes the screen darker) or bottom right button (makes the screen lighter) until suitable to read.
Faulty keypad	Replace keypad
<b>Problem:</b> Touch screen displaying “Communication Error” screen	
Communication to touch screen is faulty	Check communication wiring from bottom of touch screen (-, +, O) and confirm this is connected back to main CAREL® controller on the J25 port (-, +, O)
<b>Problem:</b> Fault light flashing red on the keypad; alarm button red on touch screen	
Fault has been detected in Vari-Flow system	Clear the faults. If the faults will not clear, there is a current fault on system. Correct the fault and then proceed to clear the fault.
<b>Problem:</b> Pollution control unit (PCU) filter status alarm	
PCU filter is clogged/full	Replace filter

## Variable Frequency Drive (VFD) Information

Yaskawa V1000 (200-230 VAC and 460 VAC) or Yaskawa A1000 (575 VAC) variable frequency drives (VFDs) will be provided if the Vari-Flow is configured to use VFDs to control the fans. These drives will come programmed from the factory, and little to no adjustment will be necessary in most cases. For more in-depth information on wiring and programming these drives, please utilize the Quick Start Guide provided with the package. This quick start guide and other technical manuals can also be found on the Yaskawa website at [www.yaskawa.com](http://www.yaskawa.com).



Parameter	Description	Default Value	Factory Adjustment
<b>b1-01</b>	Reference Source Speed Control Method	01	02
<b>b1-02</b>	Run Source – Start/Stop Control Method	01	02
<b>b1-07</b>	LOCAL/REMOTE Run Selection	00	01
<b>b1-17</b>	Run Command at Power Up	00	01
<b>C1-01</b>	Acceleration Time 1	10.00 seconds	30.00 seconds
<b>C1-02</b>	Deceleration Time 1	10.00 seconds	30.00 seconds
<b>E1-01</b>	Input Voltage	Dependent on drive type	Dependent on motor voltage*
<b>E2-01</b>	Motor Rated Current	Dependent on drive type	Dependent on motor FLA (full load amperage)*
<b>H5-01</b>	Drive Node Address	1F	Dependent on VFD address*
<b>H5-02</b>	Communication Speed Selection	03	04
<b>H5-09</b>	CE Detection Time	2.0 seconds	10.0 seconds
<b>L2-01</b>	Momentary Power Loss Operation Selection	00	02
<b>L5-01</b>	Number of Auto Restart Attempts	00	10

\*See Vari-Flow wiring diagram for more information.

### Resetting the VFD Faults

Upon a VFD fault, first determine the cause of the fault and correct. Typically, if the drive detects a fault, it will remain inoperable until that fault has been corrected and the drive has been reset.

Once a fault has been corrected, the easiest way to clear the displayed fault on the VFD is to shut off power to the drive from the power source (breaker). Wait for the VFD to fully discharge and then restore the power.

Upon correcting a minor fault, recycling power may not be necessary. Simply press , then press  twice.

Once the fault has been corrected and the drive has been reset, the main controller alarm should automatically be cleared. See page 14 for details.

## Model V1000

### Changing Parameters

**Step 1:** V1000 Digital Operator power-up state.

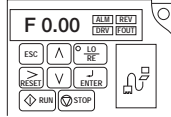

### Step 2: Select Parameter Menu

Press  $\downarrow$  two times until the digital operator show the parameter menu (PAR) then press  $\rightarrow$ .

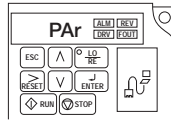

### Step 3: Select Parameter

Press  $\leftarrow$  to select the digit you would like to change. Next use  $\uparrow$  and  $\downarrow$  to select the parameter group, sub-group or number.

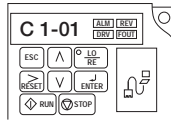

Once the parameter you wish to change is displayed on the screen and the digit furthest to the right is flashing, press  $\rightarrow$ .

### Step 4: Change Parameter Value

Press  $\leftarrow$  to select the digit of the parameter value you would like to change.

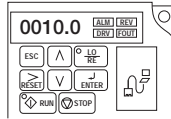

Modify the parameter value using  $\uparrow$  and  $\downarrow$  and press  $\rightarrow$  to save the new value.

## Model A1000

### Changing Parameters

**Step 1:** A1000 Digital Operator power-up state.

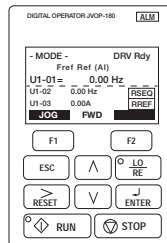

### Step 2: Select Parameter Menu

Press  $\downarrow$  two times until the digital operator shows the programming menu, then press  $\rightarrow$ .

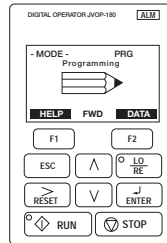

### Step 3: Select Parameter

Press  $\leftarrow$  to select the digit you would like to change. Next use  $\uparrow$  and  $\downarrow$  to select the parameter group, sub-group or number.

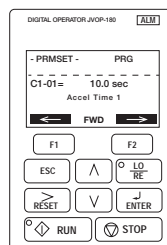

Once the parameter you wish to change is displayed on the screen and the digit furthest to the right is flashing, press  $\rightarrow$ .

### Monitor Motor Frequency and Motor Current

**Step 1:** V1000 Digital Operator power-up state:

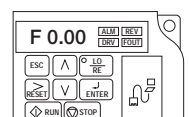

### Step 2: Output Frequency

Press  $\uparrow$  until the **FOUT** LED turns on. The display now shows the actual drive output frequency in hertz (Hz).

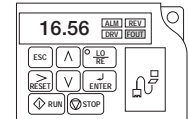

### Step 3: Motor Current

Press  $\uparrow$  again will show the motor output current. The 'A' behind the value means 'Amps'.

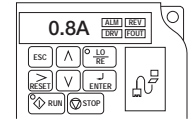

### Step 4: Change Parameter Value

Press  $\leftarrow$  to select the digit of the parameter value you would like to change.

Modify the parameter value using  $\uparrow$  and  $\downarrow$  and press  $\rightarrow$  to save the new value.

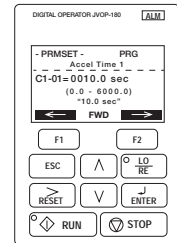

### Monitor Motor Frequency and Motor Current

With the drive running, press  $\uparrow$  until reaching the Monitor Menu. This will display output frequency and amperage of the motor.

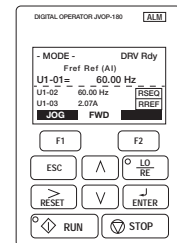

## BMS Points List • Vari-Flow v2.00 Modbus / BACnet®

Type	BACnet Device Instance: 77000 (default) Analog = AV, Integer = AV, Digital = BV			Modbus - RTU/TCP Address: 1 (default)	Read Write	Description
	Instance	Name	Units	Register		
Analog	11	H1_Ctemp	°F	40012	R	Hood 1 Control Temperature
Analog	12	H2_Ctemp	°F	40013	R	Hood 2 Control Temperature
Analog	13	H3_Ctemp	°F	40014	R	Hood 3 Control Temperature
Analog	14	H4_Ctemp	°F	40015	R	Hood 4 Control Temperature
Analog	15	H5_Ctemp	°F	40016	R	Hood 5 Control Temperature
Analog	16	H6_Ctemp	°F	40017	R	Hood 6 Control Temperature
Analog	17	H7_Ctemp	°F	40018	R	Hood 7 Control Temperature
Analog	18	H8_Ctemp	°F	40019	R	Hood 8 Control Temperature
Analog	19	H9_Ctemp	°F	40020	R	Hood 9 Control Temperature
Analog	20	H10_Ctemp	°F	40021	R	Hood 10 Control Temperature
Analog	51	Ef1_Amps	amperes	40052	R	Exhaust Fan 1 Amps from VFD
Analog	52	Ef2_Amps	amperes	40053	R	Exhaust Fan 2 Amps from VFD
Analog	53	Ef3_Amps	amperes	40054	R	Exhaust Fan 3 Amps from VFD
Analog	54	Ef4_Amps	amperes	40055	R	Exhaust Fan 4 Amps from VFD
Analog	55	Ef5_Amps	amperes	40056	R	Exhaust Fan 5 Amps from VFD
Analog	56	Ef6_Amps	amperes	40057	R	Exhaust Fan 6 Amps from VFD
Analog	57	Ef7_Amps	amperes	40058	R	Exhaust Fan 7 Amps from VFD
Analog	58	Ef8_Amps	amperes	40059	R	Exhaust Fan 8 Amps from VFD
Analog	59	Ef9_Amps	amperes	40060	R	Exhaust Fan 9 Amps from VFD
Analog	60	Ef10_Amps	amperes	40061	R	Exhaust Fan 10 Amps from VFD
Analog	71	Sf1_Amps	amperes	40072	R	Supply 1 Amps from VFD
Analog	72	Sf2_Amps	amperes	40073	R	Supply 2 Amps from VFD
Analog	73	Sf3_Amps	amperes	40074	R	Supply 3 Amps from VFD
Analog	74	Sf4_Amps	amperes	40075	R	Supply 4 Amps from VFD
Analog	81	Ef1_kW	kilowatts	40082	R	Exhaust Fan 1 Power Output
Analog	82	Ef2_kW	kilowatts	40083	R	Exhaust Fan 2 Power Output
Analog	83	Ef3_kW	kilowatts	40084	R	Exhaust Fan 3 Power Output
Analog	84	Ef4_kW	kilowatts	40085	R	Exhaust Fan 4 Power Output
Analog	85	Ef5_kW	kilowatts	40086	R	Exhaust Fan 5 Power Output
Analog	86	Ef6_kW	kilowatts	40087	R	Exhaust Fan 6 Power Output
Analog	87	Ef7_kW	kilowatts	40088	R	Exhaust Fan 7 Power Output
Analog	88	Ef8_kW	kilowatts	40089	R	Exhaust Fan 8 Power Output
Analog	89	Ef9_kW	kilowatts	40090	R	Exhaust Fan 9 Power Output
Analog	90	Ef10_kW	kilowatts	40091	R	Exhaust Fan 10 Power Output
Analog	101	Sf1_kW	kilowatts	40102	R	Supply Fan 1 Power Output
Analog	102	Sf2_kW	kilowatts	40103	R	Supply Fan 2 Power Output
Analog	103	Sf3_kW	kilowatts	40104	R	Supply Fan 3 Power Output
Analog	104	Sf4_kW	kilowatts	40105	R	Supply Fan 4 Power Output
Analog	111	Ef1_FrRe	hertz	40112	R	Exhaust Fan 1 Frequency Reference
Analog	112	Ef2_FrRe	hertz	40113	R	Exhaust Fan 2 Frequency Reference
Analog	113	Ef3_FrRe	hertz	40114	R	Exhaust Fan 3 Frequency Reference
Analog	114	Ef4_FrRe	hertz	40115	R	Exhaust Fan 4 Frequency Reference
Analog	115	Ef5_FrRe	hertz	40116	R	Exhaust Fan 5 Frequency Reference
Analog	116	Ef6_FrRe	hertz	40117	R	Exhaust Fan 6 Frequency Reference
Analog	117	Ef7_FrRe	hertz	40118	R	Exhaust Fan 7 Frequency Reference
Analog	118	Ef8_FrRe	hertz	40119	R	Exhaust Fan 8 Frequency Reference
Analog	119	Ef9_FrRe	hertz	40120	R	Exhaust Fan 9 Frequency Reference
Analog	120	Ef10_FrRe	hertz	40121	R	Exhaust Fan 10 Frequency Reference
Analog	131	Sf1_FrRe	hertz	40132	R	Supply Fan 1 Frequency Reference
Analog	132	Sf2_FrRe	hertz	40133	R	Supply Fan 2 Frequency Reference
Analog	133	Sf3_FrRe	hertz	40134	R	Supply Fan 3 Frequency Reference
Analog	134	Sf4_FrRe	hertz	40135	R	Supply Fan 4 Frequency Reference
Analog	141	Ef1_LoTemp	°F	40142	R/W	Exhaust Fan 1 Low Temperature Setting
Analog	142	Ef2_LoTemp	°F	40143	R/W	Exhaust Fan 2 Low Temperature Setting
Analog	143	Ef3_LoTemp	°F	40144	R/W	Exhaust Fan 3 Low Temperature Setting
Analog	144	Ef4_LoTemp	°F	40145	R/W	Exhaust Fan 4 Low Temperature Setting
Analog	145	EF5_LoTemp	°F	40146	R/W	Exhaust Fan 5 Low Temperature Setting
Analog	146	EF6_LoTemp	°F	40147	R/W	Exhaust Fan 6 Low Temperature Setting
Analog	147	EF7_LoTemp	°F	40148	R/W	Exhaust Fan 7 Low Temperature Setting
Analog	148	EF8_LoTemp	°F	40149	R/W	Exhaust Fan 8 Low Temperature Setting

## BMS Points List • Vari-Flow v2.00 Modbus / BACnet®

Type	BACnet Device Instance: 77000 (default) Analog = AV, Integer = AV, Digital = BV				Modbus - RTU/TCP Address: 1 (default)	Read Write	Description
	Instance	Name	Units		Register		
Analog	149	Ef9_LoTemp	°F		40150	R/W	Exhaust Fan 9 Low Temperature Setting
Analog	150	Ef10_LoTemp	°F		40151	R/W	Exhaust Fan 10 Low Temperature Setting
Analog	151	Ef1_HiTemp	°F		40152	R/W	Exhaust Fan 1 High Temperature Setting
Analog	152	Ef2_HiTemp	°F		40153	R/W	Exhaust Fan 2 High Temperature Setting
Analog	153	Ef3_HiTemp	°F		40154	R/W	Exhaust Fan 3 High Temperature Setting
Analog	154	Ef4_HiTemp	°F		40155	R/W	Exhaust Fan 4 High Temperature Setting
Analog	155	Ef5_HiTemp	°F		40156	R/W	Exhaust Fan 5 High Temperature Setting
Analog	156	Ef6_HiTemp	°F		40157	R/W	Exhaust Fan 6 High Temperature Setting
Analog	157	Ef7_HiTemp	°F		40158	R/W	Exhaust Fan 7 High Temperature Setting
Analog	158	Ef8_HiTemp	°F		40159	R/W	Exhaust Fan 8 High Temperature Setting
Analog	159	Ef9_HiTemp	°F		40160	R/W	Exhaust Fan 9 High Temperature Setting
Analog	160	Ef10_HiTemp	°F		40161	R/W	Exhaust Fan 10 High Temperature Setting
Analog	161	Ef1_LoSpeed	percent		40162	R/W	Exhaust Fan 1 Low Speed Setting
Analog	162	Ef2_LoSpeed	percent		40163	R/W	Exhaust Fan 2 Low Speed Setting
Analog	163	Ef3_LoSpeed	percent		40164	R/W	Exhaust Fan 3 Low Speed Setting
Analog	164	Ef4_LoSpeed	percent		40165	R/W	Exhaust Fan 4 Low Speed Setting
Analog	165	Ef5_LoSpeed	percent		40166	R/W	Exhaust Fan 5 Low Speed Setting
Analog	166	Ef6_LoSpeed	percent		40167	R/W	Exhaust Fan 6 Low Speed Setting
Analog	167	Ef7_LoSpeed	percent		40168	R/W	Exhaust Fan 7 Low Speed Setting
Analog	168	Ef8_LoSpeed	percent		40169	R/W	Exhaust Fan 8 Low Speed Setting
Analog	169	Ef9_LoSpeed	percent		40170	R/W	Exhaust Fan 9 Low Speed Setting
Analog	170	Ef10_LoSpeed	percent		40171	R/W	Exhaust Fan 10 Low Speed Setting
Analog	171	Ef1_HiSpeed	percent		40172	R/W	Exhaust Fan 1 High Speed Setting
Analog	172	Ef2_HiSpeed	percent		40173	R/W	Exhaust Fan 2 High Speed Setting
Analog	173	Ef3_HiSpeed	percent		40174	R/W	Exhaust Fan 3 High Speed Setting
Analog	174	Ef4_HiSpeed	percent		40175	R/W	Exhaust Fan 4 High Speed Setting
Analog	175	Ef5_HiSpeed	percent		40176	R/W	Exhaust Fan 5 High Speed Setting
Analog	176	Ef6_HiSpeed	percent		40177	R/W	Exhaust Fan 6 High Speed Setting
Analog	177	Ef7_HiSpeed	percent		40178	R/W	Exhaust Fan 7 High Speed Setting
Analog	178	Ef8_HiSpeed	percent		40179	R/W	Exhaust Fan 8 High Speed Setting
Analog	179	Ef9_HiSpeed	percent		40180	R/W	Exhaust Fan 9 High Speed Setting
Analog	180	Ef10_HiSpeed	percent		40181	R/W	Exhaust Fan 10 High Speed Setting
Analog	181	Sf1_LoSpeed	percent		40182	R/W	Supply Fan 1 Low Speed Setting
Analog	182	Sf2_LoSpeed	percent		40183	R/W	Supply Fan 2 Low Speed Setting
Analog	183	Sf3_LoSpeed	percent		40184	R/W	Supply Fan 3 Low Speed Setting
Analog	184	Sf4_LoSpeed	percent		40185	R/W	Supply Fan 4 Low Speed Setting
Analog	191	Sf1_HiSpeed	percent		40192	R/W	Supply Fan 1 High Speed Setting
Analog	192	Sf2_HiSpeed	percent		40193	R/W	Supply Fan 2 High Speed Setting
Analog	193	Sf3_HiSpeed	percent		40194	R/W	Supply Fan 3 High Speed Setting
Analog	194	Sf4_HiSpeed	percent		40195	R/W	Supply Fan 4 High Speed Setting
Integer	1011	Ef1_Speed	percent		40220	R	Exhaust Fan 1 Speed Percentage
Integer	1012	Ef2_Speed	percent		40221	R	Exhaust Fan 2 Speed Percentage
Integer	1013	Ef3_Speed	percent		40222	R	Exhaust Fan 3 Speed Percentage
Integer	1014	Ef4_Speed	percent		40223	R	Exhaust Fan 4 Speed Percentage
Integer	1015	Ef5_Speed	percent		40224	R	Exhaust Fan 5 Speed Percentage
Integer	1016	Ef6_Speed	percent		40225	R	Exhaust Fan 6 Speed Percentage
Integer	1017	Ef7_Speed	percent		40226	R	Exhaust Fan 7 Speed Percentage
Integer	1018	Ef8_Speed	percent		40227	R	Exhaust Fan 8 Speed Percentage
Integer	1019	Ef9_Speed	percent		40228	R	Exhaust Fan 9 Speed Percentage
Integer	1020	Ef10_Speed	percent		40229	R	Exhaust Fan 10 Speed Percentage
Integer	1031	Sf1_Speed	percent		40240	R	Supply Fan 1 Speed Percentage
Integer	1032	Sf2_Speed	percent		40241	R	Supply Fan 2 Speed Percentage
Integer	1033	Sf3_Speed	percent		40242	R	Supply Fan 3 Speed Percentage
Integer	1034	Sf4_Speed	percent		40243	R	Supply Fan 4 Speed Percentage
			Inactive_Text	Active_Text			
Digital	10	GLOBAL_ALARM	Off	Alarm	10011	R	Global Alarm
Digital	11	Sys1_On_Off	Off	On	10012	R/W	Hood System 1 On/Off (0: Off; 1: On)
Digital	12	Sys2_On_Off	Off	On	10013	R/W	Hood System 2 On/Off (0: Off; 1: On)
Digital	13	Sys3_On_Off	Off	On	10014	R/W	Hood System 3 On/Off (0: Off; 1: On)
Digital	14	Sys4_On_Off	Off	On	10015	R/W	Hood System 4 On/Off (0: Off; 1: On)

## BMS Points List • Vari-Flow v2.00 Modbus / BACnet®

Type	BACnet Device Instance: 77000 (default) Analog = AV, Integer = AV, Digital = BV				Modbus - RTU/TCP Address: 1 (default)	Read Write	Description
	Instance	Name	Units		Register		
Digital	15	Sys5_On_Off	Off	On	10016	R/W	Hood System 5 On/Off (0: Off; 1: On)
Digital	16	Sys6_On_Off	Off	On	10017	R/W	Hood System 6 On/Off (0: Off; 1: On)
Digital	17	Sys7_On_Off	Off	On	10018	R/W	Hood System 7 On/Off (0: Off; 1: On)
Digital	18	Sys8_On_Off	Off	On	10019	R/W	Hood System 8 On/Off (0: Off; 1: On)
Digital	19	Sys9_On_Off	Off	On	10020	R/W	Hood System 9 On/Off (0: Off; 1: On)
Digital	20	Sys10_On_Off	Off	On	10021	R/W	Hood System 10 On/Off (0: Off; 1: On)
Digital	91	T1_Alm	Off	Alarm	10092	R	Temp Sensor 1 Failure
Digital	92	T2_Alm	Off	Alarm	10093	R	Temp Sensor 2 Failure
Digital	93	T3_Alm	Off	Alarm	10094	R	Temp Sensor 3 Failure
Digital	94	T4_Alm	Off	Alarm	10095	R	Temp Sensor 4 Failure
Digital	95	T5_Alm	Off	Alarm	10096	R	Temp Sensor 5 Failure
Digital	96	T6_Alm	Off	Alarm	10097	R	Temp Sensor 6 Failure
Digital	97	T7_Alm	Off	Alarm	10098	R	Temp Sensor 7 Failure
Digital	98	T8_Alm	Off	Alarm	10099	R	Temp Sensor 8 Failure
Digital	99	T9_Alm	Off	Alarm	10100	R	Temp Sensor 9 Failure
Digital	100	T10_Alm	Off	Alarm	10101	R	Temp Sensor 10 Failure
Digital	101	Fire_Alm	Off	Alarm	10102	R	Fire System Status (0: Ok; 1: Fire)
Digital	102	Rem_En	Off	On	10103	R/W	Remote Enable (0: Off; 1: On)
Digital	103	Wash_En	Off	On	10104	R/W	Wash Enable (0: Off; 1: On)
Digital	104	Fill_det	Off	Alarm	10105	R	Detergent Status (0: Ok; 1: Empty)
Digital	105	CWM_status	Off	On	10106	R	Cold Water Mist Status (0: Off; 1: On)
Digital	106	PCU_filter_1	Off	Alarm	10107	R	PCU Filter 1 Status (0: Ok; 1: Clogged)
Digital	107	PCU_filter_2	Off	Alarm	10108	R	PCU Filter 2 Status (0: Ok; 1: Clogged)
Digital	108	PCU_filter_3	Off	Alarm	10109	R	PCU Filter 3 Status (0: Ok; 1: Clogged)
Digital	131	Sf1_Af_Alm	Off	Alarm	10132	R	Airflow Alarm Supply Fan 1
Digital	132	Sf2_Af_Alm	Off	Alarm	10133	R	Airflow Alarm Supply Fan 2
Digital	133	Sf3_Af_Alm	Off	Alarm	10134	R	Airflow Alarm Supply Fan 3
Digital	134	Sf4_Af_Alm	Off	Alarm	10135	R	Airflow Alarm Supply Fan 4
Digital	141	Sf1_Pres_Alm	Off	Alarm	10142	R	Supply Fan 1 Pressure Alarm
Digital	160	HiTemp_Alm	Off	Alarm	10161	R	High Temperature Alarm
Digital	161	Exh_BO_Alm	Off	Alarm	10162	R	Exhaust Starter/VFD Fault
Digital	162	Sup_BO_Alm	Off	Alarm	10163	R	Supply Starter/VFD Fault
Digital	163	Exh_VBF_Alm	Off	Alarm	10164	R	Exhaust VFD By Factory Fault
Digital	164	Sup_VBF_Alm	Off	Alarm	10165	R	Supply VFD By Factory Fault
Digital	171	Ef1_Status	Off	On	10172	R	Exhaust Fan 1 Status
Digital	172	Ef2_Status	Off	On	10173	R	Exhaust Fan 2 Status
Digital	173	Ef3_Status	Off	On	10174	R	Exhaust Fan 3 Status
Digital	174	Ef4_Status	Off	On	10175	R	Exhaust Fan 4 Status
Digital	175	Ef5_Status	Off	On	10176	R	Exhaust Fan 5 Status
Digital	176	Ef6_Status	Off	On	10177	R	Exhaust Fan 6 Status
Digital	177	Ef7_Status	Off	On	10178	R	Exhaust Fan 7 Status
Digital	178	Ef8_Status	Off	On	10179	R	Exhaust Fan 8 Status
Digital	179	Ef9_Status	Off	On	10180	R	Exhaust Fan 9 Status
Digital	180	Ef10_Status	Off	On	10181	R	Exhaust Fan 10 Status
Digital	181	Sf1_Status	Off	On	10182	R	Supply Fan 1 Status
Digital	182	Sf2_Status	Off	On	10183	R	Supply Fan 2 Status
Digital	183	Sf3_Status	Off	On	10184	R	Supply Fan 3 Status
Digital	184	Sf4_Status	Off	On	10185	R	Supply Fan 3 Status

## BMS Points List • Vari-Flow v2.00 LonWorks®

Type	NV_Index/Bit	Name NV	Type NV	Read (Unit to BMS) Write (BMS to Unit)	Description
Analog	15	nvoH1_Ctemp	105	Read	Hood 1 Control Temperature
Analog	16	nvoH2_Ctemp	105	Read	Hood 2 Control Temperature
Analog	17	nvoH3_Ctemp	105	Read	Hood 3 Control Temperature
Analog	18	nvoH4_Ctemp	105	Read	Hood 4 Control Temperature
Analog	19	nvoH5_Ctemp	105	Read	Hood 5 Control Temperature
Analog	20	nvoH6_Ctemp	105	Read	Hood 6 Control Temperature
Analog	21	nvoH7_Ctemp	105	Read	Hood 7 Control Temperature
Analog	22	nvoH8_Ctemp	105	Read	Hood 8 Control Temperature
Analog	23	nvoH9_Ctemp	105	Read	Hood 9 Control Temperature
Analog	24	nvoH10_Ctemp	105	Read	Hood 10 Control Temperature
Integer	25	nvoEf1_Speed	81	Read	Exhaust Fan 1 Speed Percentage
Integer	26	nvoEf2_Speed	81	Read	Exhaust Fan 2 Speed Percentage
Integer	27	nvoEf3_Speed	81	Read	Exhaust Fan 3 Speed Percentage
Integer	28	nvoEf4_Speed	81	Read	Exhaust Fan 4 Speed Percentage
Integer	29	nvoEf5_Speed	81	Read	Exhaust Fan 5 Speed Percentage
Integer	30	nvoEf6_Speed	81	Read	Exhaust Fan 6 Speed Percentage
Integer	31	nvoEf7_Speed	81	Read	Exhaust Fan 7 Speed Percentage
Integer	32	nvoEf8_Speed	81	Read	Exhaust Fan 8 Speed Percentage
Integer	33	nvoEf9_Speed	81	Read	Exhaust Fan 9 Speed Percentage
Integer	34	nvoEf10_Speed	81	Read	Exhaust Fan 10 Speed Percentage
Integer	35	nvoSf1_Speed	81	Read	Supply Fan 1 Speed Percentage
Integer	36	nvoSf2_Speed	81	Read	Supply Fan 2 Speed Percentage
Integer	37	nvoSf3_Speed	81	Read	Supply Fan 3 Speed Percentage
Integer	38	nvoSf4_Speed	81	Read	Supply Fan 4 Speed Percentage
Digital	39	nvoGLOBAL_ALARM	81	Read	Global Alarm
Digital	3	nviSys1_On_Off	95	Write	Hood System 1 On/Off (0: Off; 1: On)
Digital	4	nviSys2_On_Off	95	Write	Hood System 2 On/Off (0: Off; 1: On)
Digital	5	nviSys3_On_Off	95	Write	Hood System 3 On/Off (0: Off; 1: On)
Digital	6	nviSys4_On_Off	95	Write	Hood System 4 On/Off (0: Off; 1: On)
Digital	7	nviSys5_On_Off	95	Write	Hood System 5 On/Off (0: Off; 1: On)
Digital	8	nviSys6_On_Off	95	Write	Hood System 6 On/Off (0: Off; 1: On)
Digital	9	nviSys7_On_Off	95	Write	Hood System 7 On/Off (0: Off; 1: On)
Digital	10	nviSys8_On_Off	95	Write	Hood System 8 On/Off (0: Off; 1: On)
Digital	11	nviSys9_On_Off	95	Write	Hood System 9 On/Off (0: Off; 1: On)
Digital	12	nviSys10_On_Off	95	Write	Hood System 10 On/Off (0: Off; 1: On)
Digital	13	Rem_En	95	Write	Remote Enable (0: Off; 1: On)
Digital	14	nviwash_En	95	Write	Wash Enable (0: Off; 1: On)
	40	nvoTmp_Snsr_Alms	83		Temperature Sensor Alarms
Digital	(LSB) bit0	T1_Alm		Read	Temp Sensor 1 Failure
Digital	bit1	T2_Alm		Read	Temp Sensor 2 Failure
Digital	bit2	T3_Alm		Read	Temp Sensor 3 Failure
Digital	bit3	T4_Alm		Read	Temp Sensor 4 Failure
Digital	bit4	T5_Alm		Read	Temp Sensor 5 Failure
Digital	bit5	T6_Alm		Read	Temp Sensor 6 Failure
Digital	bit6	T7_Alm		Read	Temp Sensor 7 Failure
Digital	bit7	T8_Alm		Read	Temp Sensor 8 Failure
Digital	bit8	T9_Alm		Read	Temp Sensor 9 Failure
Digital	bit9	T10_Alm		Read	Temp Sensor 10 Failure
Digital	41	Fire_Alm	95	Read	Fire System Status (0: Ok; 1: Fire)
Digital	42	nvoFill_det	95	Read	Detergent Status (0: Ok; 1: Empty)
Digital	43	nvoCWM_status	95	Read	Cold Water Mist Status (0: Off; 1: On)

## BMS Points List • Vari-Flow v2.00 LonWorks®

Type	NV_Index/Bit	Name NV	Type NV	Read (Unit to BMS) Write (BMS to Unit)	Description
	44	nvoPCU_FilterAlm	83		PCU Filter Alarms
Digital	(LSB) bit0	PCU_filter_1		Read	PCU Filter 1 Status (0: Ok; 1: Clogged)
Digital	bit1	PCU_filter_2		Read	PCU Filter 2 Status (0: Ok; 1: Clogged)
Digital	bit2	PCU_filter_3		Read	PCU Filter 3 Status (0: Ok; 1: Clogged)
Digital	45	Sf1_Pres_Alm		Read	Supply Fan 1 Pressure Alarm
Digital	46	nvoHiTemp_Alm	95	Read	High Temperature Alarm
	47	nvoAirProvAlms	83		Supply Airflow Proving Alarms
Digital	(LSB) bit0	Sf1_Af_Alm		Read	Airflow Alarm Supply Fan 1
Digital	bit1	Sf2_Af_Alm		Read	Airflow Alarm Supply Fan 2
Digital	bit2	Sf3_Af_Alm		Read	Airflow Alarm Supply Fan 3
Digital	bit3	Sf4_Af_Alm		Read	Airflow Alarm Supply Fan 4
	48	nvoVFDAIm	83		Supply Airflow Proving Alarms
Digital	(LSB) bit0	Exh_BO_Alm		Read	Exhaust Starter/VFD Fault
Digital	bit1	Sup_BO_Alm		Read	Supply Starter/VFD Fault
Digital	bit2	Exh_VBF_Alm		Read	Exhaust VFD By Factory Fault
Digital	bit3	Sup_VBF_Alm		Read	Supply VFD By Factory Fault
	49	nvoEF_Status	83		Exhaust Fans Status
Digital	(LSB) bit0	Ef1_Status		Read	Exhaust Fan 1 Status
Digital	bit1	Ef2_Status		Read	Exhaust Fan 2 Status
Digital	bit2	Ef3_Status		Read	Exhaust Fan 3 Status
Digital	bit3	Ef4_Status		Read	Exhaust Fan 4 Status
Digital	bit4	Ef5_Status		Read	Exhaust Fan 5 Status
Digital	bit5	Ef6_Status		Read	Exhaust Fan 6 Status
Digital	bit6	Ef7_Status		Read	Exhaust Fan 7 Status
Digital	bit7	Ef8_Status		Read	Exhaust Fan 8 Status
Digital	bit8	Ef9_Status		Read	Exhaust Fan 9 Status
Digital	bit9	Ef10_Status		Read	Exhaust Fan 10 Status
	50	nvoSF_Status	83		Supply Fans Status
Digital	(LSB) bit0	Sf1_Status		Read	Supply Fan 1 Status
Digital	bit1	Sf2_Status		Read	Supply Fan 2 Status
Digital	bit2	Sf3_Status		Read	Supply Fan 3 Status
Digital	bit3	Sf4_Status		Read	Supply Fan 4 Status

## Our Commitment

*As a result of our commitment to continuous improvement, Greenheck reserves the right to change specifications without notice.*

Product warranties can be found online at [Greenheck.com](http://Greenheck.com), either on the specific product page or in the literature section of the website at [Greenheck.com/Resources/Library/Literature](http://Greenheck.com/Resources/Library/Literature).

Greenheck's Kitchen Ventilation Systems, Controls and Energy Management catalog provides additional information describing the equipment, fan performance, available accessories, and specification data.

AMCA Publication 410-96, Safety Practices for Users and Installers of Industrial and Commercial Fans, provides additional safety information. This publication can be obtained from AMCA International, Inc. at [www.amca.org](http://www.amca.org).

