

**FIRE PROTECTION
FOR RESTAURANT AND
COMMERCIAL COOKING
EQUIPMENT**



ANSUL

RESTAURANT

**THE FIRE-ATTACKING
RESTAURANT SYSTEM**



Pioneers in Restaurant Fire System Technology

Prior to 1962, many restaurant fires went unchecked. Recognizing this problem, Ansul engineers designed the first dry chemical fire suppression systems specifically for restaurant kitchens. The Ansul R-100 and R-101 systems soon became standard protection for kitchen hoods, ducts, and appliances. They were so effective that insurance companies eventually required a system in every restaurant they insured.

In 1982, Ansul introduced the R-102 system which featured a new extinguishing agent called ANSULEX®. Like the dry chemical used in the R-101 system, the ANSULEX agent rapidly knocked down the flame and formed a frothy blanket over the appliance surface. Plus, because ANSULEX was a wet chemical, it also cooled the fuel surface.

UL 300 - A Challenge for System Manufacturers

As restaurant fire protection systems have evolved, so have the kitchens they protect. The preparation of low cholesterol and low fat foods requires the use of hotterburning vegetable oils. Highly insulated, slow-cooling appliances have also become more commonplace. As a result, fires in today's appliances are more difficult to extinguish and secure than in the past.

Underwriters Laboratories recently addressed this problem in their updated Standard for Fire Extinguishing Systems for Protection of Restaurant Cooking Areas: UL-300.

To pass UL's more stringent fire tests, today's systems must provide significantly more extinguishing agent to extinguish the fire and prevent reignition - larger or additional agent containers - and more discharge nozzles for each appliance, particularly for deep-fat fryers.



PIRANHA™...The Challenge is Met

The company that invented restaurant fire protection has developed a better way to protect restaurant and commercial kitchens.

Traditional wet chemical systems rely on a fixed amount of agent to both extinguish the fire and prevent it from reigniting while the fuel slowly cools. Water spray systems provide a cooling effect, but are slow to knock down the flame.

PIRANHA systems attack fire using the best of both extinguishing methods... The rapid flame knockdown and securing ability of new PRX™ liquid fire suppressant - PLUS the superior cooling effects of water.

How the PIRANHA™ System Operates.

- 1 High heat from a fire in an appliance causes a fusible link detector to separate.
- 2 The detection system triggers the ANSUL AUTOMAN® release mechanism which simultaneously pressurizes the agent tank and operates any auxiliary gas or power shut-off devices.
- 3 PRXTM liquid agent flows through the pipe and is discharged through the nozzles onto the appliance surfaces and into the hood, plenum and ductwork. This new, proprietary, wet chemical agent knocks down the flame in a matter of seconds and reacts with the hot grease to form a vapor-suppressing blanket.
- 4 Approximately ten seconds after system actuation, the agent tank valve automatically switches from agent to water flow. Following the same path as the agent through the pipe and nozzles, the water discharge rapidly cools the fuel and surrounding surfaces.

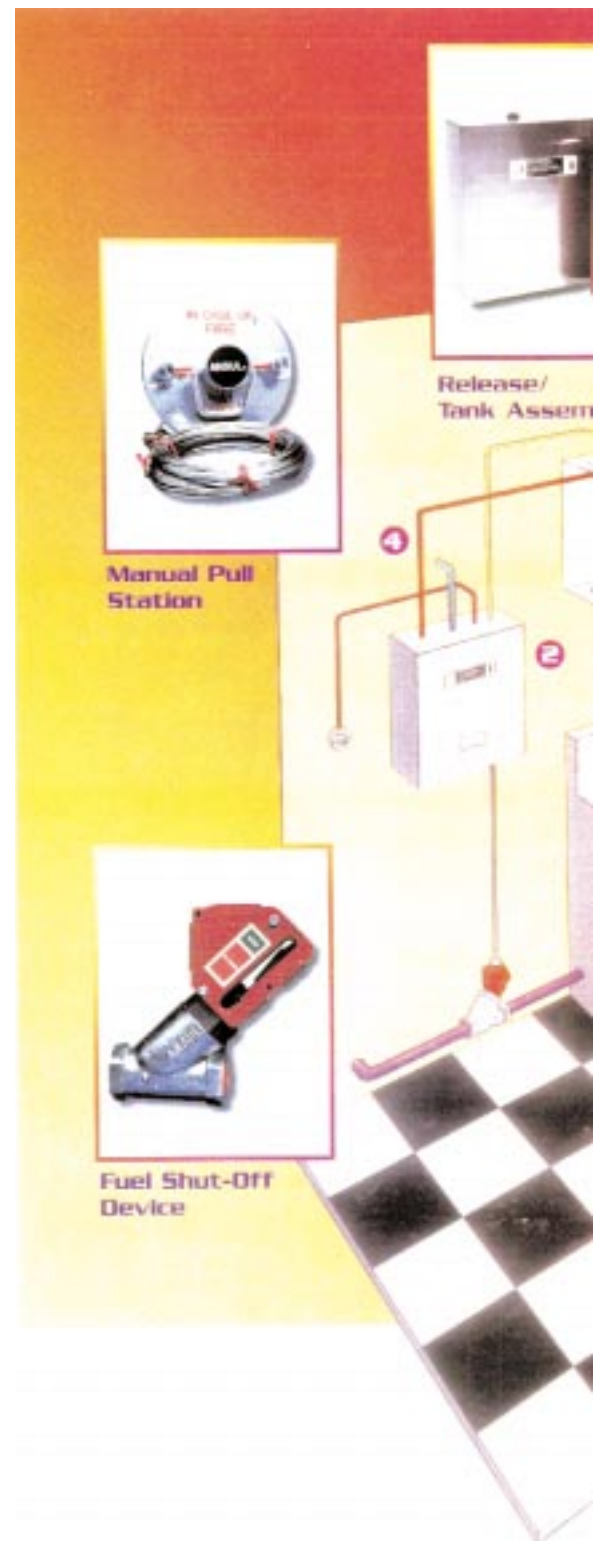



Detection Components



Nozzles and Fittings

The PIRANHA™ Advantage

Due to its rapid flame knockdown, securing, and cooling effects; PIRANHA systems offer many advantages over traditional fire protection systems.

Extremely Fast Cooling

In approximately one minute, the PIRANHA system typically reduces the temperature of the cooking oil or grease below its autoignition temperature. That's about 15 times faster than conventional wet chemical systems where the fuel may remain hot enough to reignite for as long as 15 minutes after discharge.



Advanced Agent Technology

PRX™ liquid fire suppressant was specifically formulated and tested for use with the PIRANHA system. It rapidly knocks down the flames and simultaneously forms a vapor-securing blanket on the fuel surface. Plus, because PRX is a "water enhanced agent," the thickness of the foam blanket actually increases during the water discharge.

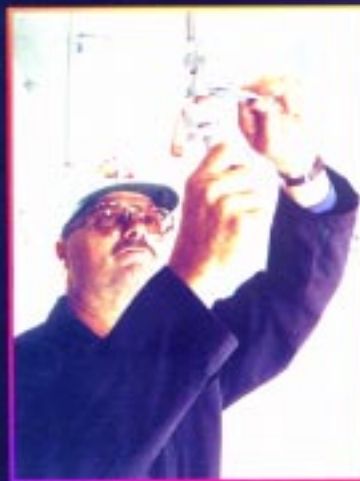

Flexible Nozzle and Appliance Placement

With PIRANHA systems, nozzle quantity and placement requirements are much more flexible. In most cases, the nozzles can be placed in a straight-line overlapping arrangement to protect appliances of various types and sizes. Even if appliances are later replaced or rearranged, they are still properly protected as long as they remain under the system's zone of protection.

Code & Standard Compliance

- Underwriters Laboratories, Inc. (UL) Test Standards 300 and 2092
- Underwriters Laboratory of Canada (ULC)
- NFPA 17A: Standard for Wet Chemical Extinguishing Systems
- NFPA 96: Standard for Ventilation Control and Fire Protection of Commercial Cooking Operations
- American Society of Sanitation Engineers (ASSE): Cross Connection Protection Devices
- International Association of Plumbing and Mechanical Code Officials (IAPMO): Guide for Restaurant Fire Suppression Systems, 113-97.

Protection For Virtually Any Restaurant or Commercial Cooking Area

Typical PIRANHA™ 7 System (Up to 10 ft. (3.04 m) Hood Length)

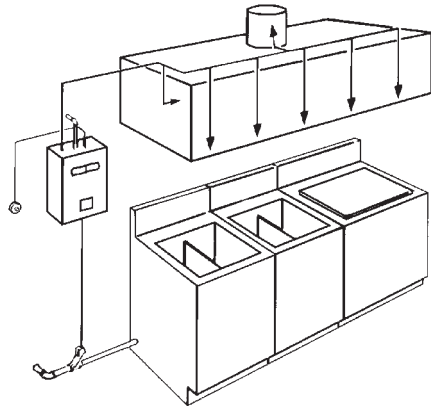

System Requirements

- One PIRANHA 7 Tank/Release
- Seven Discharge Nozzles
- One Fuel Shut-Off Valve
- Five Fusible Link Detectors
- One Remote Pull Station

Typical Applications

- Diner
- Convenience Store
- Food Court
- Bar & Grill



Typical PIRANHA™ 10 System (UP to 14 ft. (4.26 m) Hood Length)

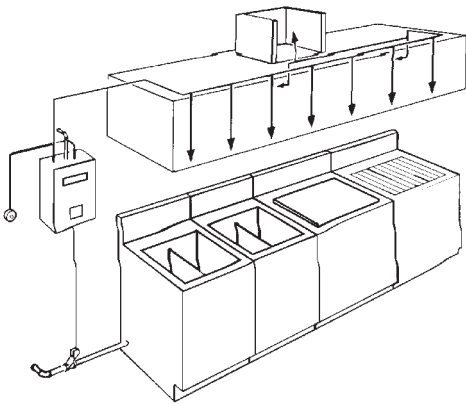

System Requirements

- One PIRANHA 10 Tank/Release
- Ten Discharge Nozzles
- One Fuel Shut-Off Valve
- Eight Fusible Link Detectors
- One Remote Pull Station

Typical Applications

- Fast-Food Restaurant
- Family Restaurant
- Caterer's Kitchen
- School Cafeteria



Typical PIRANHA™ 13 System (UP to 18 ft. (5.48 m) Hood Length)

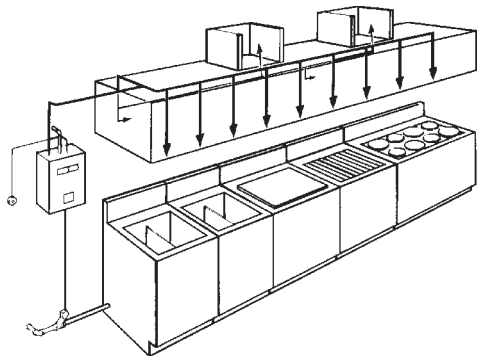

System Requirements

- One PIRANHA 13 Tank/Release
- Thirteen Discharge Nozzles
- One Fuel Shut-Off Valve
- Eleven Fusible Link Detectors
- One Remote Pull Station

Typical Applications

- Hospital
- Hotel/Convention Center
- Culinary School/Institution
- Sports Complex



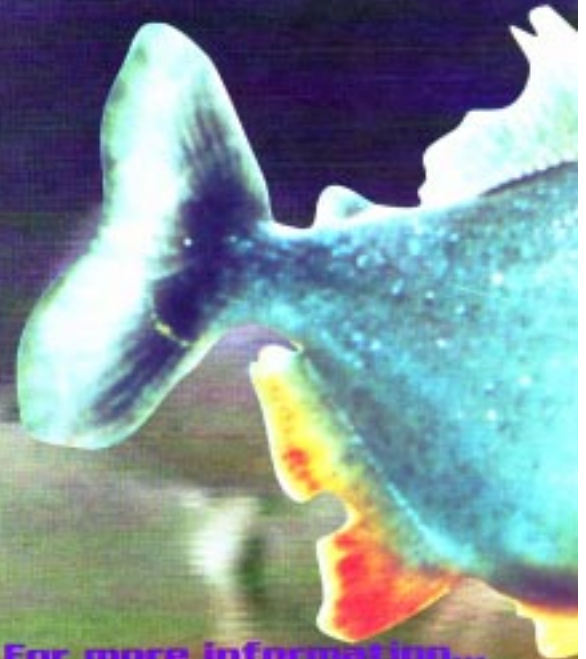

For more information...

*Check your local Yellow Pages for
your authorized Award Restaurant
Systems Distributor.*

Or call Ansul direct at...

1-800-TO-ANSUL

(Toll-Free USA/CA/NI)

or

1-715-735-7411

USA FAX: 478-735-7412

INTL FAX: 478-735-7411



ANSUL®
Experts In Global Fire Solutions

ISO 9001 REGISTERED

ANSUL INCORPORATED
ONE STANTON STREET
MARINETTE, WI 54143-2542

A tyco INTERNATIONAL LTD. COMPANY

ANSUL is a registered trademark. PRIMA and PPS are trademarks.

© 1998 Tyco International Ltd. All rights reserved.

www.ansul.com