

Engineered Kitchen Ventilation Systems

Auto Scrubber Hood System

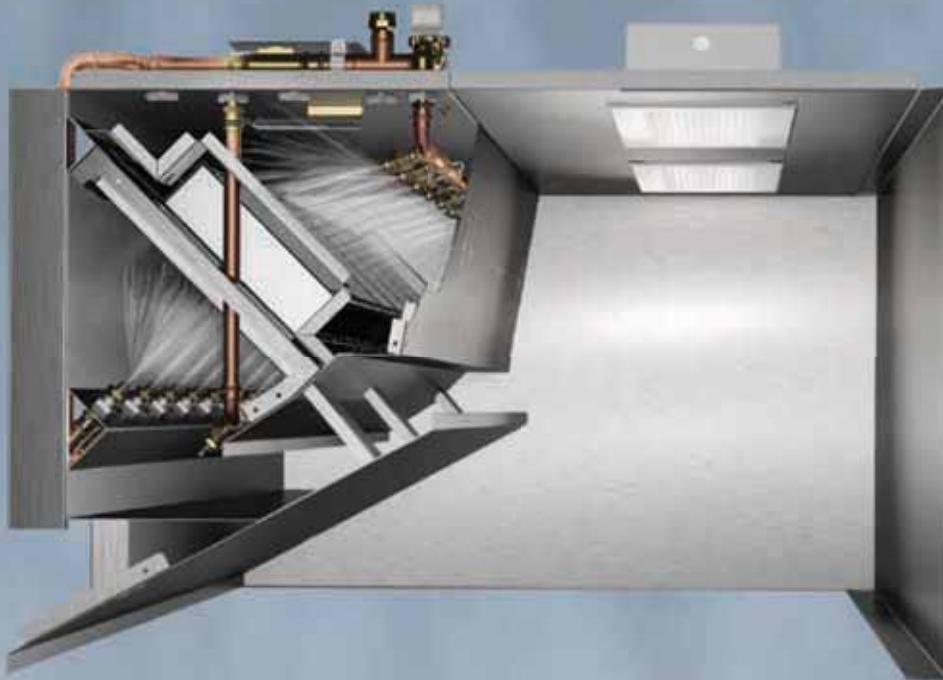

BUILDING VALUE IN AIR.



August
2016

A clean cooking environment leads to increased productivity, safety, health and well-being, but sometimes the most important areas to clean are the most difficult, expensive and time consuming, like a commercial kitchen hood. We have created the Auto Scrubber to give you a self-cleaning hood that's easy to use, efficient, and cost effective.

Applications

- Heavy grease producing appliances such as: charbroilers, woks, fryers, griddles
- Facilities with long duct runs and long hours of operation
- Use in conjunction with Pollution Control Units to reduce maintenance costs (replacement filters)

Benefits

- Dramatically reduces operating costs by decreasing frequency of filter, hood, and duct cleanings
- Superior clean-in-place filter technology
- Premium grease extraction efficiency
- Increased safety – reduced fire risk, no need to manually remove filters

1 Main water nozzles clean both sides of filters

2 Cold water mist

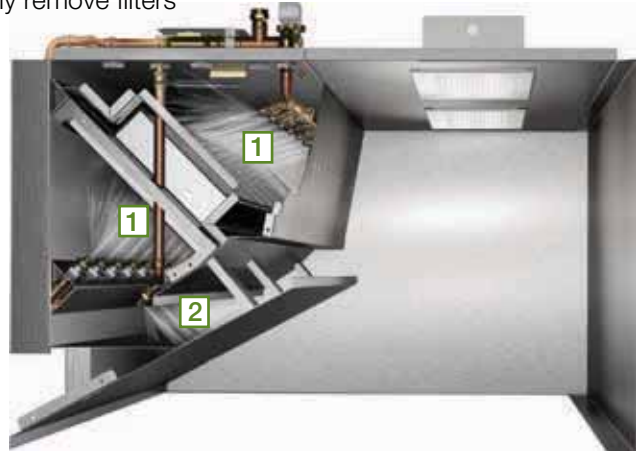

Superior Filter Cleaning

- Cleans **both** sides of the filters in place
 - Set of nozzles on both sides of the filters
 - Eliminates daily removal and manual cleaning of grease filters
 - Prevents unsafe removal of filters as there is no need to climb on top of appliances to do so
 - Reduces number of professional cleanings required for hood and duct system
- Results in a drastic reduction of grease build-up not only on filters, but ductwork and fans
 - Decreases the potential for fire

Easy Maintenance

- Filters and fire system components are easily inspected and serviced via tool-less access panels
- 2.5 gallon detergent tank decreases time spent replacing detergent
- Large 2-inch gravity drain captures grease from the pitched grease trough further reducing grease build-up and its associated maintenance



Versatile Filtration

- Can be used with any of Greenheck's filters

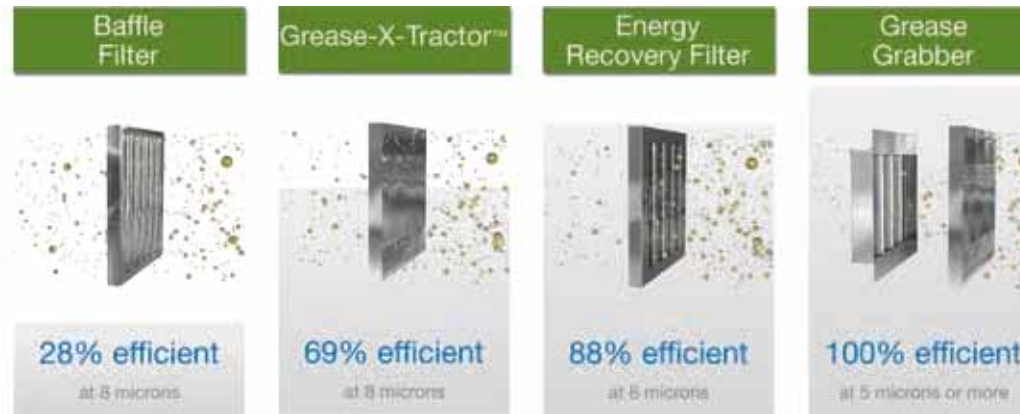

- Continuous Cold Water Mist (optional)
 - For use in solid fuel applications to knockdown sparks and reduce the temperature of the exhaust airstream, thus preventing baking grease onto the filters

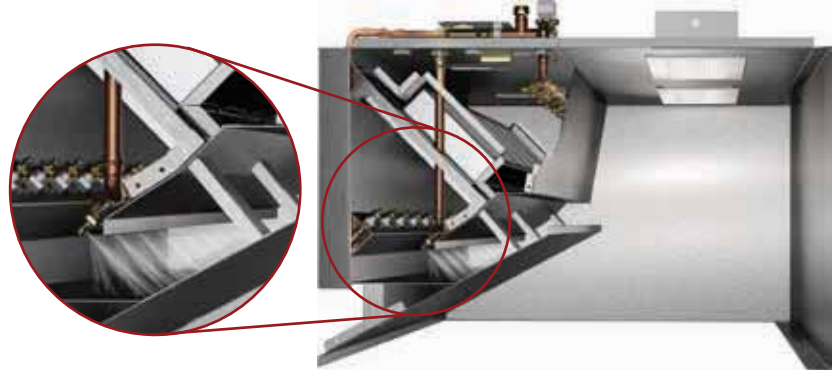

Connected

- Control panel
 - Controls up to four hood sections
 - Remote mounted or hood utility cabinet mounted
- Wash controls are integrated with your choice of fan control
 - Wash Only (no fan control)
 - Basic (no starters/VFDs)
 - Kitchen Fan Control Center (starters)
 - Vari-Flow (VFD)
- BMS Integration
 - LONworks®, BACnet® MSTP/IP, or Modbus
- User Interfaces
 - Keypad
 - Touch Screen



Auto Scrubber Control Panel (ASCP)



Auto Scrubber Hood System



Our Commitment

As a result of our commitment to continuous improvement, Greenheck reserves the right to change specifications without notice.

Specific Greenheck product warranties are located on greenheck.com within the product area tabs and in the Library under Warranties.



P.O. Box 410 • Schofield, WI 54476-0410 • Phone (715) 359-6171 • greenheck.com



Prepared to Support
Green Building Efforts

00.KIT.1016 R1 8-2016 RG
Copyright © 2016 Greenheck Fan Corp.