

Kitchen Ventilation Systems

- Exhaust Hoods & Grease Extraction
- Fire Suppression Systems
- Accessories







BUILDING VALUE IN AIR.

 **GREENHECK**
Building Value in Air.

November
2015

Greenheck’s comprehensive line of kitchen ventilation products are designed to meet the varying needs of foodservice establishments. Whether you are working on a school cafeteria, restaurant, industrial cooking process, or otherwise, Greenheck has the products and resources to meet your ventilation requirements. Additionally, Greenheck offers exhaust fans, make-up air units and more to create a complete, quality kitchen ventilation system.

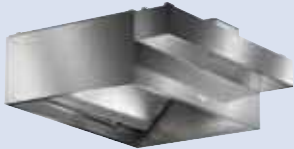
To learn about our controls, utility distribution systems and other products, see the kitchen ventilation catalogs identified on the back cover and visit www.greenheck.com.

Model	Application	Pages
<p>Grease Hoods – Type I</p> 	<p>Type I kitchen hoods are used over cooking equipment producing grease-laden effluent.</p>	5-12
<p>Heat & Condensate Hoods – Type II</p> 	<p>Type II kitchen hoods are designed to capture heat and/or condensate from non-grease producing appliances such as ovens and dishwashers.</p>	13-16
<p>Grease Extraction</p> 	<p>Greenheck offers industry-leading grease extraction filters to match your cooking application.</p>	17-25
<p>External Supply Plenums</p> 	<p>Greenheck has a variety of solutions available to properly introduce air into the space when exhaust-only hoods are being used.</p>	26-28
<p>Residential Range Fire Suppression</p> 	<p>Greenheck’s Fire Ready Hood is a dual purpose device. It is both a ventilation hood and a self-contained fire suppression system. It is designed for use above residential style appliances in commercial settings.</p>	29
<p>Fire Suppression Systems</p> 	<p>The first line of defense against fire in a commercial kitchen is the hood fire protection system. Greenheck has a variety of factory pre-piped fire protection systems available from the two leading manufacturers, Amerex® and Ansul®.</p>	30-31

1. Will you be exhausting grease-laden air or non-grease-laden air?

- **Type I Hoods:** Used if you are exhausting grease-laden air.



- **Type II Hoods:** Used if you are exhausting non-grease-laden air (heat/condensate).



2. Type I Hoods: What hood style do I need?

Is your cooking equipment against a wall?

- **Wall canopy hoods:**

Most common when the cooking battery is against a wall.



Wall Canopy Hood

- **Proximity (backshelf) hoods:**

Used when you have a low ceiling and/or it is to be placed over light to medium duty cooking equipment such as ranges, griddles and fryers. These hoods are typically used in quick service restaurants.



Proximity (Backshelf) Hood

Is your cooking equipment located in the open (example, island)?

- **Single-island hoods:**

Used when the cooking battery is in one row, not against a wall.



Single-Island Hood

- **Double-island hoods:**

Used when the cooking battery is in two back-to-back rows, not against a wall.



Double-Island Hood

Type II Hoods: What hood style do I need?

- **Heat and fume:**

Heat-only hoods are typically used for oven applications.



Heat and Fume

- **Condensate:**

Condensate hoods are typically used above dishwashers.



Condensate

Grease Hoods — Type I



 Greenheck Type I hoods are UL 710 Listed.
US LISTED



Type I Overview

Type I hoods are designed for use above grease-producing equipment and are available in several styles and configurations.

Greenheck grease hoods offer the following benefits:

- Standard construction is a minimum of 18 gauge 430 stainless steel
- Hoods can be built in single section lengths from 3-16 feet (914-4,876 mm)
- Flexible lengths, widths and heights
 - Hood lengths:* Available in 1-inch (25 mm) increments
 - Hood widths:* Available in 3-inch (76 mm) increments
 - Hood heights:* Available in 24-inch (609 mm), 30-inch (762 mm) or tapered configurations
- Longer hoods are available in multiple sections and can be made to appear as one hood by utilizing our continuous capture option to improve performance and aesthetics
- Standing seam construction for superior strength
- Excellent dimensional tolerances due to highly tooled manufacturing
- UL 710 Listed and bears the National Sanitation Foundation (NSF) Seal of Approval (Standard 2)
- Rated for 400°F (76°C), 600°F (316°C), and 700°F (371°C) cooking operations
- Performance Enhancing Lip (PEL) is standard and improves capture efficiency by turning air back into the hood

Model Number Code

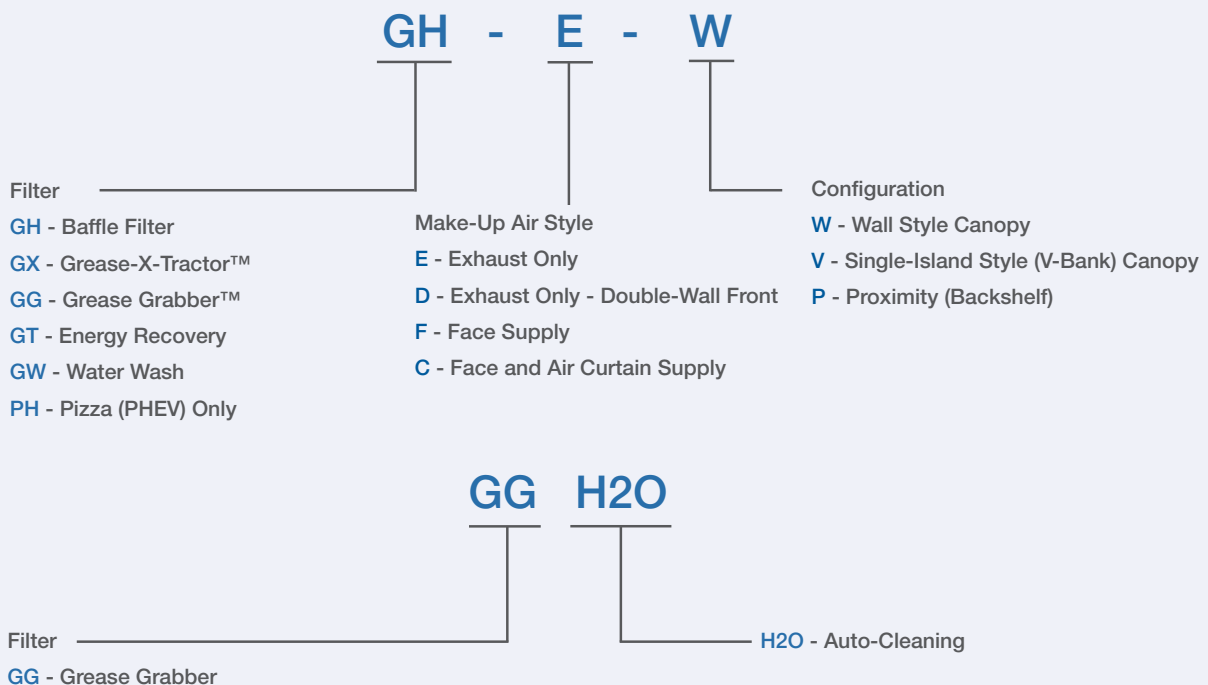

Wall Canopy Hoods

Greenheck's wall canopy hoods are used over cooking equipment that produce heat and grease-laden effluent. Wall canopy hoods are intended to be used when the cooking equipment is placed against a wall. A wide variety of sizing and hood options, along with several accessories, make Greenheck the right choice to meet your range of design requirements.

Exhaust Only

- Supply air is introduced through ceiling diffusers or external supply plenums (shown on page 26-28)
- More dimensional flexibility than other manufacturers

Single-Wall Front

Double-Shell Front (Optional)

- One-inch of insulation between stainless steel panels provides additional strength and rigidity



Face Supply

- Supply air is introduced horizontally through the face via perforated panels in a manner that does not interfere with the cooking operation beneath the hood(s)
- Perforated panels are located on the face to ensure uniform distribution and will limit the throw to within several feet of the hood(s)
- Provides a higher level of dimensional flexibility than other manufacturers



Face and Air Curtain Supply

- Supply air is introduced both horizontally through the face and vertically through the front perimeter via perforated panels in a manner that does not interfere with the cooking operation beneath the hood(s)
- Perforated panels ensure uniform distribution and will limit the throw to within several feet of the hood(s)



Auto-Cleaning Hood

Typical grease hoods, though low-cost up front, carry many overlooked and expensive maintenance issues that can lead to high costs over their lifespan. Capturing the grease generated by cooking processes is a challenge and the clean-up of grease is both costly and time consuming.

Grease Grabber™ H₂O System Benefits



- Proven Grease Grabber dual-stage filtration technology
- No manual filtration removal, resulting in labor savings
- Filter maintenance is automatically carried out
- Programmable timer allows for cleaning to be completed on a set schedule or by the push of a button
- The Grease Grabber H₂O's recirculation method reduces hot water consumption by 50% helping to reduce operating costs

How it Works - Extracting the Grease

Grease Grabber H₂O utilizes the Greenheck Grease Grabber™ dual stage filtration system which consists of an Greenheck Grease-X-Tractor™ filter in conjunction with Greenheck Grease Grabber filter. Together, this filtration system provides the best mechanical grease extraction in the industry.

The Grease-X-Tractor is the primary filter and takes the brunt of the grease and heat. The proprietary design of the filter provides greater strength, thereby making it the best fire barrier in the industry. The Grease-X-Tractor extracts 69% of grease particles at 8 microns from the effluent airstream.

The Grease Grabber, acting as a secondary filter, uses a 1/2 inch packed bead bed to remove smaller particles that pass through the Grease-X-Tractor. Together this system removes 100% of the grease at 5 microns and larger (smoke to spatter).

Cleaning the Hoods and Filters

The Grease Grabber H₂O's innovative auto-cleaning system is a highly efficient, closed system that combines time-saving convenience with cost reductions related to labor, water and energy use.

Upon activation of the cleaning cycle, the system fills a tank in the hood with a hot water/detergent mixture. The system washes the filter banks and plenum using specifically aimed spray nozzles located throughout the plenum area. The mix is recycled through the system by a high-efficiency pump, purged and then the hood is rinsed with fresh hot water.

- No need for a gravity drain
- Detergent is biodegradable so waste water can be drained to a standard grease trap
- All plumbing and controls are factory-installed in an end-mounted utility cabinet for ease of installation
- Options for remote utility cabinets are available

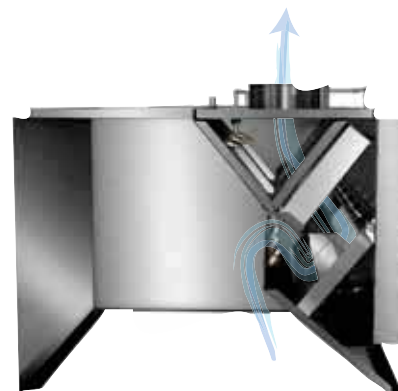

Grease Grabber H₂O Keypad

Proximity (Backshelf) Hoods

Greenheck proximity hoods have an industry-leading five dimensions of adjustment which make them the perfect solution for low ceilings and light to medium duty cooking applications. The Greenheck proximity hood sits close to the cooking equipment allowing for lower exhaust rates and smaller hoods.

Proximity hoods are designed for grease- and heat-laden effluent (Type I), and are shorter in height and width than a canopy hood. The name “Proximity” or “Backshelf” refers to the close proximity of the hood with respect to the cooking equipment. In addition, Greenheck proximity hoods have an optional plate shelf and/or pass-over enclosure to meet your design requirements.



Single-Island (V-Bank) Canopy Hoods

Greenheck’s single-island style canopy hoods are used over cooking equipment that produces heat- and grease-laden effluent (Type I). Single-island style canopy hoods are used over one row of cooking equipment placed where no walls exist. Single-island hoods can be seen from all directions and have four finished (all stainless steel) sides available in both V-bank and single-bank filter configurations. Greenheck offers a variation of the single-island hood for use over pizza ovens. Contact your Greenheck representative for more information.

Exhaust Only - Single-Wall

- Supply air is introduced through ceiling diffusers or external supply plenums



Face Supply

- Make-up air is supplied horizontally through the face via perforated panels in a manner that does not interfere with the cooking operation beneath the hood(s)
- Perforated panels are located on the face to ensure uniform distribution and will limit the throw to within several feet of the hood



Specialty Hoods

Greenheck offers many specialty hoods such as radius corners, heavier gauges and hoods with cladding. Contact your Greenheck representative to discuss your specific requirements.



Options & Accessories for Grease Hoods

Filtration Options – A variety of filtration options are available with increasing grease extraction efficiencies to suit specific needs. See our Grease Extraction section on pages 17-25 for more detail.

External Supply Plenums* – Several supply plenum options are available to supply air back to the space evenly. See External Supply Plenums section on pages 26-28 for more detail.

Continuous Capture* – Provides a UL Listed bolted connection allowing end-to-end hoods to be connected and appear as one hood.



Material Options* – Standard construction is stainless steel where exposed and galvanized steel in the unexposed plenum. 100% stainless steel construction is available. Either option is available in 300 series stainless steel or 430 stainless steel.

Lighting Options* – Multiple lighting options are available. Screw in for incandescent or CFL fixtures are standard. Recessed incandescent and 2-, 3-, or 4-foot recessed fluorescent fixtures are also available. All fixtures are vapor proof and UL Approved.

LED lighting provides a bright, warm light for cooking and a significantly longer operating life. LED lights save up to 95% in electrical costs when compared to using standard incandescent lights in a kitchen hood.



Tapered Hood* – Tapered fronts are available for low ceiling applications.

Tapered Fronts (inches)	Required Overhang (inches)
12	12
15	12
18	6



Exhaust Collars –

- **Factory-Mounted** – Collars are fully welded to the exhaust plenum and include a 1 inch flange.
- **Ship Loose** – Exhaust collars are included, but not mounted to the hood. This enables the contractor to locate and cut the exhaust opening, where desired, without knowing ahead of time.
- **Shape** – To accommodate various ductwork, several sizes of rectangular and round collars are available.
- **Location*** – Top or back placement for mounted exhaust collars.

Supply Collars –

- **Additional Collars*** – To maintain lower supply airflow velocities around the hood, additional supply collars can be added.
- **Shape (Round or Rectangle)** – To accommodate various ductwork, different sized collars are available on most supply plenums in both round and rectangular shapes.

Ceiling Enclosure – When the top of the hood is mounted lower than the finished ceiling height, enclosure panels can be provided to match your hood. Enclosure panels are easy to install with factory-provided hardware.



Backsplash Panels/Side Splash Panels – Provide an aesthetically desirable and easily cleanable stainless steel surface behind or on adjacent walls near the hood. Constructed of 300 series stainless steel or 430 stainless steel to match the hood. Optional insulated panels are available.



*See Options & Accessories chart on page 12 for specific options for Grease Hoods — Type I

Options & Accessories for Grease Hoods

End Skirts* – End skirts are available in both full and mini configurations. End skirts lower required exhaust rates as they improve capture.



Airspace/Filler Panels – To achieve required clearances to combustible surfaces, stainless steel airspaces can be supplied. These panels can also be used to fill-in open spaces and improve aesthetics.



Exhaust Air Balancing Baffles* – Used to help balance exhaust airflows between multiple ducts or hood sections being exhausted through one duct line. Air balancing baffles can be mounted at the exhaust collar openings which allow the exhaust opening to be up to 50% closed.



Switches* – Switches can be shipped loose for remote mounting, mounted on the hood face, or on the utility cabinet.

Finished Back* – With most wall canopy hoods, hanging is done against a wall, making the need for an aesthetically pleasing finished back unnecessary. For instances in which the back is visible, the same finish as the other three sides of the hood can be provided.

Insulated Supply Plenum* – With some plenums, condensation can occur from bringing in cold air near to where hot air is being exhausted. By insulating these plenums, problems with condensation are alleviated. This also helps prevent cooler incoming air from being heated by warmer exhaust air.

Automatic Fire Damper* – In areas where exhaust fire dampers are required, a UL Listed motorized butterfly damper that closes at 280°F (140°C) can be installed in the exhaust collar.

Utility Cabinets Hood Mount/Wall Mount*
Utility cabinets for fire systems and/or control mounting can be attached to the left or right side of the hood. Remote (wall mount) cabinets are also available.



Filter Removal Tool*
Used to enable operators to safely reach and remove filters from the hood while standing on the floor in front of appliances.



Trim Strips* – Stainless steel strips that can be used anywhere hood sections meet to improve aesthetics.

Zero Clearance – Our new clearance reduction system utilizes a one-inch wide (thick) insulating material on the front, back, sides, and top of the hood as needed. This provides great value, especially in retrofit building applications. Our Zero Clearance system allows new hoods to be mounted closer to combustible surfaces, such as cabinetry and wood roof trusses, while satisfying both safety standards and codes.



*See Options & Accessories chart on page 12 for specific options for Grease Hoods — Type I

Options & Accessories for Grease Hoods

Options Guide	Make-Up Air Style	Wall Canopy				Single-Island (V-Bank)		Proximity (Backshelf)
		Exhaust Only		Face Supply	Face and Air Curtain Supply	Exhaust Only	Face Supply	Exhaust Only
		Single-Wall	Double-Wall					
Options and Accessories	Model	--EW	--DW	--FW	--CW	--EV	--FV	--EP
Grease Grabber™ Multistage Filtration System	GG--	Optional	Optional	Optional	Optional	Optional	Optional	Optional
Energy Recovery Filter	GT--	Optional	Optional	—	—	—	—	—
Grease-X-Tractor™ Centrifugal Filtration	GX--	Optional	Optional	Optional	Optional	Optional	Optional	Optional
Baffle Filter	GH--	Optional	Optional	Optional	Optional	Optional	Optional	Optional
Water Wash Hood	GW--	Optional	Optional	Optional	Optional	—	—	—
Horizontal Supply Plenum (HSP)	—	Optional	Optional	—	—	Optional	—	Optional
Air Curtain Supply Plenum (ASP)	—	Optional	Optional	—	—	Optional	—	—
Variable Supply Plenum (VSP)	—	Optional	Optional	—	—	Optional	—	—
Back Supply Plenum (BSP)	—	Optional	Optional	Optional	Optional	—	—	Optional
Continuous Capture	—	Optional	Optional	Optional	Optional	—	—	Optional
Material Options	—	Optional	Optional	Optional	Optional	Optional	Optional	Optional
Lighting Options	—	Optional	Optional	Optional	Optional	Optional	Optional	—
Additional Supply Duct Collars	—	—	—	Optional	Optional	—	Optional	—
Tapered Hood	—	Optional	Optional	—	—	Optional	—	—
*Supply Collar Shape Round/Rectangle	—	—	—	Optional	Optional	—	Optional	—
Exhaust Collar (Ship Loose)	—	Optional	Optional	Optional	Optional	Optional	Optional	Optional
Exhaust Collar Location (Back)	—	Optional	Optional	Optional	Optional	—	—	Optional
Exhaust Collar Shape	—	Optional	Optional	Optional	Optional	Optional	Optional	Optional
Switches	—	Optional	Optional	Optional	Optional	Optional	Optional	Optional
Ceiling Enclosures	—	Optional	Optional	Optional	Optional	Optional	Optional	Optional
Utility Cabinets Hood Mount/Wall Mount	—	Optional	Optional	Optional	Optional	Optional	Optional	Wall Mount Only
Backsplash Panels/Sidesplash Panels	—	Optional	Optional	Optional	Optional	—	—	Optional
End Skirt	—	Optional	Optional	Optional	Optional	Optional	Optional	Optional
Airspace/Filler Panels	—	Optional	Optional	Optional	Optional	Optional	Optional	Optional
Exhaust Air Balancing Baffles	—	Optional	Optional	Optional	Optional	Optional	Optional	Optional
Finished Back	—	Optional	Optional	Optional	Optional	—	—	Optional
Insulated Supply Plenum	—	—	—	Optional	Optional	—	Optional	—
Automatic Fire Damper	—	Optional	Optional	Optional	Optional	Optional	Optional	Optional
Filter Removal Tool	—	Optional	Optional	Optional	Optional	Optional	Optional	Optional
Trim Strips	—	Optional	Optional	Optional	Optional	Optional	Optional	Optional
Zero Clearance	—	Optional	Optional	Optional	Optional	Optional	Optional	Optional

*Round supply collars are not available on back supply plenums.

Model Grease Grabber H₂O is available with all options except tapered hood, back exhaust collar location and filter removal tool.

Heat & Condensate Hoods — Type II



Overview & Typical Applications

Type II hoods are designed to capture heat and/or condensate from non-grease producing appliances such as ovens and dishwashers.

Greenheck heat and condensate hoods offer the following benefits:

- The National Sanitation Foundation (NSF) Seal of Approval (Standard 2)
- Standard construction is a minimum of 18 gauge 430 stainless steel
- Flexible lengths, widths and heights
 - Hood lengths:* Available in 1-inch (25 mm) increments
 - Hood widths:* Available in 3-inch (76 mm) increments
 - Hood heights:* Available in 12-30 (350-762 mm) inches and 3-inch (76 mm) increments
- Standing seam construction for superior strength
- Excellent dimensional tolerances due to highly tooled manufacturing

Model Number Code

GO
|
—

Greenheck Hood Type II

GO - Oven, General Ventilation

GD1 - Condensate - No Baffle

GD2 - Condensate - Single-Baffle

GD3 - Condensate - Double-Baffle

Non-Filtered Heat and Fume Hoods

Model GO

Primarily used for ovens or general ventilation applications to capture heat and vapor, creating a more comfortable environment for the cooking staff.



Condensate Hoods

Models GD1, GD2 & GD3

- Primarily used for dishwasher or condensate applications to capture heat and vapor, creating a more comfortable environment for the cooking staff
- These hoods are constructed with a gutter and drain
- The condensate hoods are available in three styles:
 - No Baffles (model GD1)** - Most economical and flexible in condensate applications
 - Single-Baffle (model GD2)** - Designed for moderate condensation applications. Great for vertical door dishwasher applications.
 - Double-Baffle (model GD3)** - Designed for heavy condensate applications



Options & Accessories

Material Options – Standard construction is in 300 series stainless steel or 430 stainless steel.

Incandescent Lighting* – UL Listed vapor proof incandescent light fixtures are available.



External Supply Plenums* – Several supply plenum options are available to supply air evenly back to the space. See External Supply Plenums section on pages 26-28 for more detail.

Mesh Filter* – With most Type II hoods, the exhaust opening is exposed. Adding a mesh filter in the exhaust collar helps prevent anything other than heat and moisture from passing through the duct opening.



Exhaust Collars –

- **Factory-Mounted** – Collars are fully-welded to the exhaust plenum and include a 1 inch flange.
- **Ship Loose** – Exhaust collars are included but not mounted to the hood. This enables the contractor to locate and cut the exhaust opening, where desired, without knowing ahead of time.
- **Shape** – To accommodate various ductwork, several sizes of rectangular and round collars are available.

Switches* – Greenheck Type II hoods allow for switch mounting in a cabinet attached to the hood or as a remote option.

Ceiling Enclosure – When the top of the hood is mounted lower than the finished ceiling height, enclosure panels can be provided to match your hood. Enclosure panels are easy to install with factory-provided hardware.



Trim Strips – Stainless steel strips to be used anywhere hood sections meet to improve aesthetics.

Utility Cabinets Hood Mount/Wall Mount – Utility cabinets for control mounting can be attached to the left or right side of the hood. All hoods can be supplied with a cabinet to be remote mounted in the space.



Backsplash Panels/Side Splash Panels – Provide an aesthetically desirable and easily cleanable stainless steel surface behind or on adjacent walls near the hood. Constructed of 300 series stainless steel or 430 stainless steel to match the hood. Optional insulated panels are available.



End Skirts* – Available in both full and mini configurations, end skirts lower required exhaust rates as they improve capture.



Airspace/Filler Panels – These panels are used to fill in open spaces and improve aesthetics.



Exhaust Air Balancing Baffles –

To help balance exhaust airflows between multiple ducts or hood sections being exhausted through one duct line. Air balancing baffles can be mounted at the exhaust collar openings which allow the exhaust opening to be up to 50% closed.



*See Options & Accessories chart on page 16 for specific options for Heat and Condensate Hoods – Type II

Options & Accessories

Options Guide	Heat/Oven	Condensate		
		No Baffle	Single Baffle	Double Baffle
Options and Accessories	Model GO	Model GD1	Model GD2	Model GD3
Incandescent Lighting	Optional	Optional	Optional	—
Horizontal Supply Plenum (HSP)	Optional	Optional	Optional	Optional
Air Curtain Supply Plenum (ASP)	Optional	Optional	Optional	Optional
Variable Supply Plenum (VSP)	Optional	Optional	Optional	Optional
Back Supply Plenum (BSP)	Optional	Optional	Optional	Optional
Mesh Filter	Optional	Optional	—	—
Exhaust Collar (Ship Loose)	Optional	Optional	Optional	Optional
Exhaust Collar Shape	Optional	Optional	Optional	Optional
Switches	Optional	Optional	Optional	—
Ceiling Enclosures	Optional	Optional	Optional	Optional
Utility Cabinets Hood Mount/Wall Mount	Optional	Optional	Optional	Optional
Backsplash Panels/Sidesplash Panels	Optional	Optional	Optional	Optional
End Skirt	Optional	Optional	Optional	Optional
Airspace/Filler Panels	Optional	Optional	Optional	Optional
Exhaust Air Balancing Baffles	Optional	Optional	Optional	Optional
Trim Strips	Optional	Optional	Optional	Optional

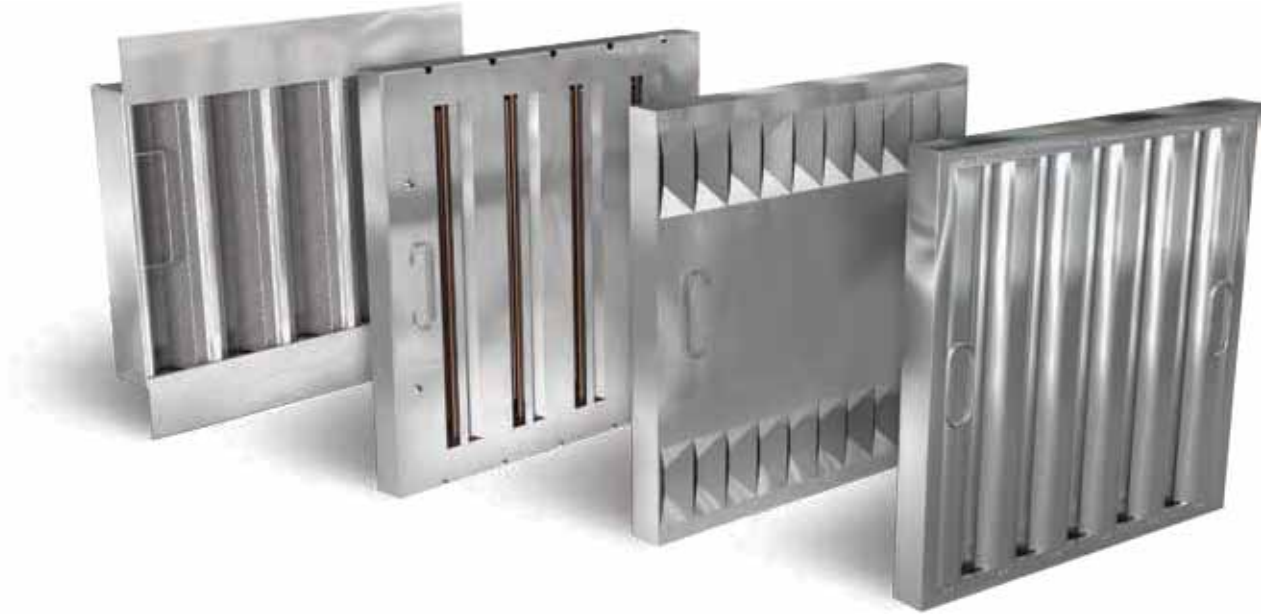





 Greenheck filters are UL 1046 Listed.
US LISTED



Filtration Options

Greenheck is the industry leader in grease filtration as verified by testing to ASTM F2519-2005 standards. This is crucial to the restaurant owner/operator because the grease generated by restaurant kitchens pose many problems: frequent duct cleaning, rooftop grease problems and compliance with tougher air emissions standards. Greenheck's offering of innovative filter designs attack the problem at the source for a fraction of the cost of other grease removal devices or electrostatic precipitators.

Filter	Application	Example Appliances	Static Pressure (9 x 4 foot hood at 2050 cfm)	Grease Removal Efficiency* at 8 microns	Grease Removal Efficiency* at 3-10 microns
 <p>Grease Grabber™ Multistage Filtration System</p>	Heavy to Extra Heavy Duty Grease	Solid Fuel Cooking Appliances Upright Broiler Gas, Electric & Lava Rock Char-Broiler Mesquite Infrared Broiler Wok Chain Broiler	1.1 to 1.3 in. wg	100%	99%
 <p>Energy Recovery Filter</p> <p>Back Front</p>	Medium to Heavy Duty Grease	Gas & Electric Ovens/ Steamers/Ranges Food Warmers Pizza Ovens	0.6 to 0.7 in. wg	88%	60%
 <p>Grease-X-Tractor™ Centrifugal Filtration</p>	Medium to Heavy Duty Grease	Combination Ovens Gas & Electric Fryers Griddles Grill Up-right Broiler Electric Char-Broiler	0.7 to 0.8 in. wg	69%	51%
 <p>Baffle</p>	Light Duty Grease	Gas & Electric Ovens/ Steamers/Ranges Food Warmers Pizza Ovens	0.5 to 0.6 in. wg	28%	16%

*See Efficiency Charts on pages 20-24.

What is in my Kitchen's Exhaust? Grease Defined.

Total kitchen exhaust includes all grease particulate sizes as well as grease vapors. Grease is the by-product of commercial cooking processes that must be extracted from the effluent airstream via the kitchen ventilation system.

Grease can be broken down into three different categories:

- **Submicron particles:** Produced when a drop of grease or water comes in contact with a hot surface and immediately burns off. Particle sizes range from 0.03 to 0.55 microns (smoke).
- **Steam:** Grease covered moisture and air mixture is produced by the long burning of cold or frozen food on a hot cooking surface. Particle sizes range from 0.55 to 6.2 microns.
- **Spatter:** Larger more visible effluent that is produced during the cooking process. Particle sizes range from 6.2 to 150 microns.

Research and testing has determined that a significant concentration of grease particles can be found in the submicron and steam phases. Most currently applied grease extraction devices remove very large grease particulate that is 10 to 150 microns in size (spatter phase), but are not capable of removing fine particulates that are found in the submicron and steam phases.

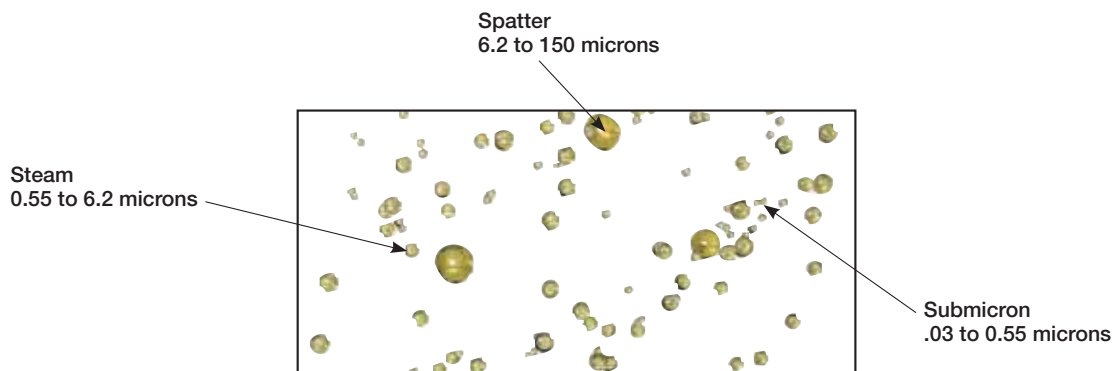

Testing of Grease Extraction Devices

Older grease filter efficiency tests designed to test the efficiency of a grease filter did not effectively portray the full range of particles produced during the cooking operation. This led to the development of test Standard ASTM F2519-2005. This test shows the entire spectrum of the filter's efficiency from 0.3 to 100 microns. The efficiency is expressed as a graph similar to a fan curve rather than using one percentage to cover all size particles.

ASTM F2519-2005 Standard Test Method for Grease Particle Capture Efficiency of Commercial Kitchen Filters and Extractors is the first universally accepted test method in the commercial kitchen ventilation industry that covers efficiency testing of both removable filters and fixed extractors, such as water wash hoods.

ASTM F2519-2005 tests generate a controlled quantity of particles in sizes ranging from 0.3 to 10 microns, that are released into a kitchen hood to represent the cooking effluent. The particles are then sampled and counted downstream in the ductwork with an optical particle counter, with and without the extractor in place. These are used to calculate the fractional efficiency versus the particle size.

The efficiency graphs that Greenheck uses reflect the test methods used in ASTM F2519-2005.

Grease Extraction Efficiency

Grease Extraction Efficiency vs. Particle Size
600 CFM

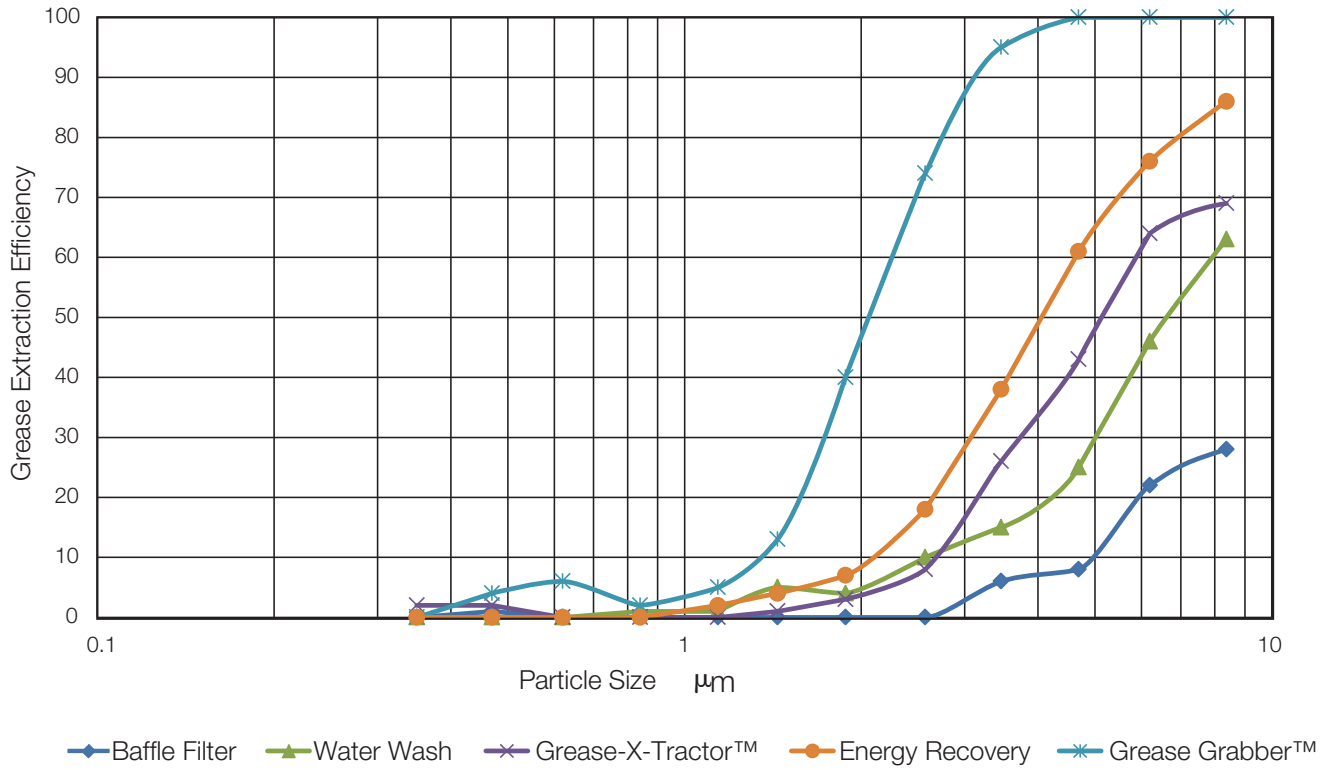

Grease Grabber™ Multistage Filtration System

The Grease Grabber dual-stage filtration system uses the Grease-X-Tractor along with the Grease Grabber filter to remove 100% of the grease particles, at 5 microns and larger, out of the airstream. The Grease Grabber system is designed for heavy-duty grease applications.

How it works:

The **Grease-X-Tractor** is the primary filter that removes large grease particles using centrifugal force (described on page 22).

The **Grease Grabber** is the secondary filter that uses a ½-inch packed bead bed to remove the small particles of grease that are not removed by the Grease-X-Tractor filter.



- Tested to ASTM F2519-2005
- UL 1046 Listed
- NSF Certified

Grease-X-Tractor with Grease Grabber removes 100% of the grease particles at 5 microns or larger

Mass & Grease Extraction Efficiency vs. Particle Size for Grease Grabber™ Over Griddle with Hamburger

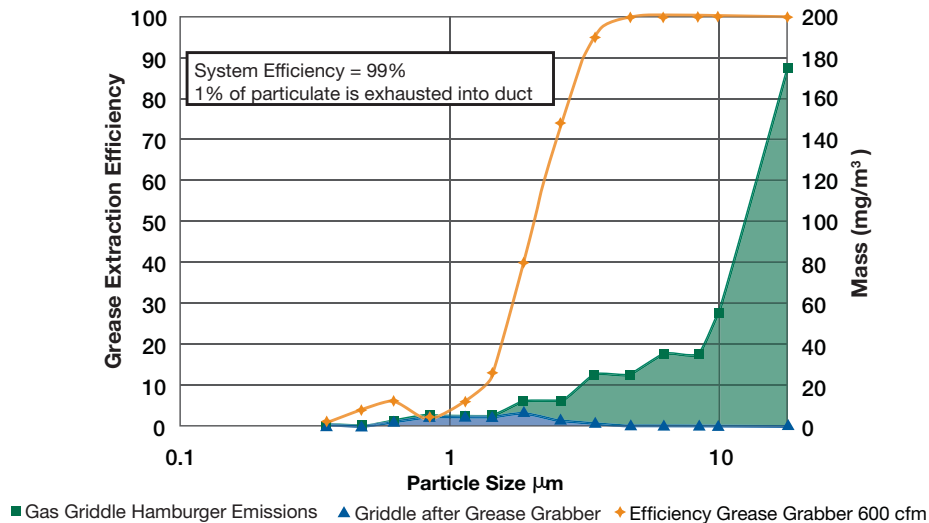

See Third-Party Grease Extraction Efficiency Verification on page 25

Grease-X-Tractor™ Centrifugal Filtration

The Grease-X-Tractor filter is the ideal filter for medium grease-loading applications. The design of the filter gives the filter great strength and makes it the best fire barrier in the industry, removing 69% of the grease particles at 8 microns.

How it works:

- The **Grease-X-Tractor** filter consists of individual vortex chambers having air inlets at the top and bottom front of the filter.
- Air travels in a helical or corkscrew like path through the filter chambers, subjecting the grease particulate to centrifugal force and throwing it out of the airstream.
- Grease collects on the interior walls of the filter, which then drains into the hood grease trough and grease cup.

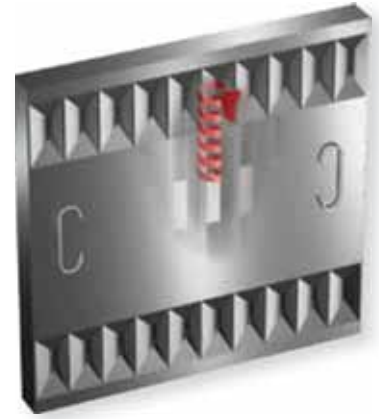

- Tested to ASTM F2519-2005 standard method of test
- UL 1046 Listed
- NSF Certified

The Grease-X-Tractor removes 69% of the grease particles at 8 microns

Mass & Grease Extraction Efficiency vs. Particle Size for Grease-X-Tractor™ Over Griddle with Hamburger

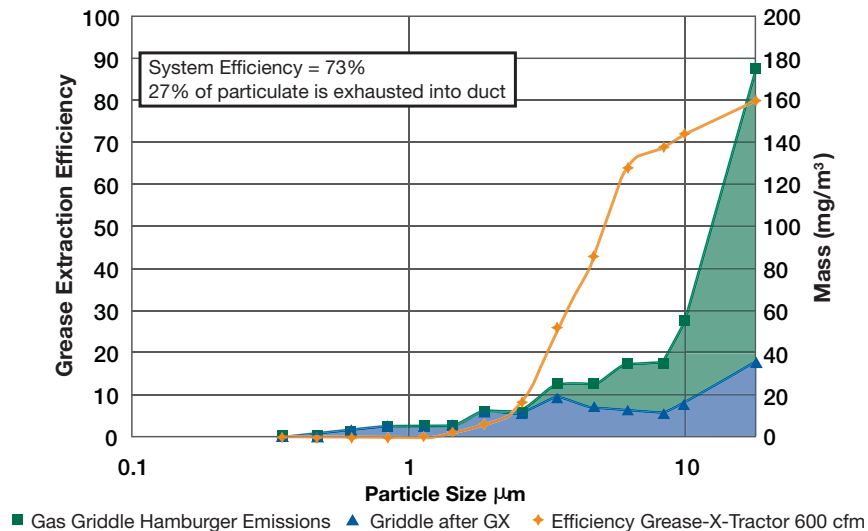

See Third-Party Grease Extraction Efficiency Verification on page 25

Energy Recovery Filter

The energy recovery filter is designed for medium duty grease applications.

How it works:

- A portion of your incoming cold water is directed through a control panel which directs 2-3.5 gpm of water to the hood and the remaining water to your hot water heater.
- The water enters the hood and travels through the energy recovery filters which have heat exchangers built into them.
- As the hot exhaust air passes over the heat exchanger's coils, the water captures the waste heat from the airstream
- The pre-heated water exits the hood and is sent to the hot water heater.

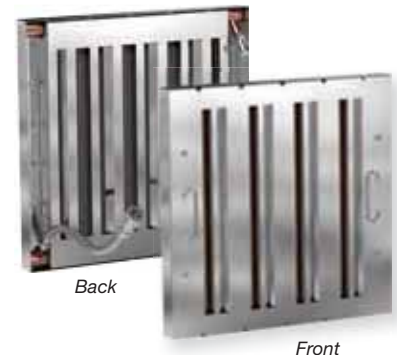

U.S. Patent 8,728,189,82

Saves Energy

- As the water travels through the hood, it will be pre-heated by the exhaust airstream achieving a 25-40°F temperature rise.
- The preheated water is sent to the hot water heater where it requires less natural gas to heat the water up to the required operating temperature.
- Less natural gas required to heat incoming water equals lower monthly utility bills.



Saves Money

- The cooling temperatures at the filters condense more of the grease vapor.
- More grease removed by the filters reduces the grease accumulation in the duct and plenum which means fewer duct cleanings and expenses.



- UL 1046 Listed
- NSF Certified

The energy recovery filter removes 88% of the grease particles at 8 microns

Standard Baffle

The industry standard baffle filter is designed for light-duty grease applications.

How it works:

- Exhaust air passes through the aluminum/stainless steel baffles.
- As the air turns, the particle's momentum throws the particle out of the airstream as it changes direction, causing the particulates to impact upon the baffles.
- The grease then runs down the baffle into the grease trough, which then drains into a removable grease container.



- Tested to ASTM F2519-2005 standard method of test
- UL 1046 Listed
- NSF Certified

The baffle filter removes 28% of the grease particles at 8 microns

Mass & Grease Extraction Efficiency vs. Particle Size for Baffle Over Griddle with Hamburger

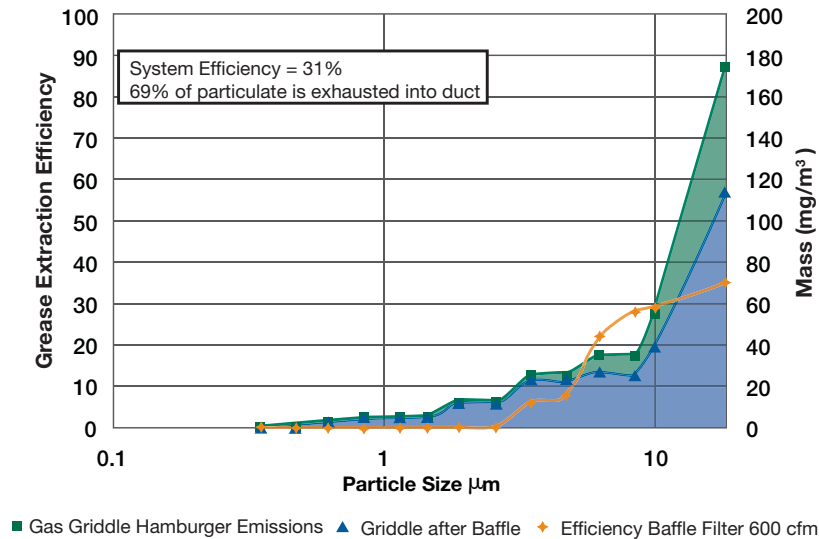

See Third-Party Grease Extraction Efficiency Verification on page 25

Grease Extraction by Cooking Equipment Type

Different appliances and types of food will produce different amounts of grease, so there is a need for different levels of grease extraction efficiency.

Greenheck recommends filters for each type of cooking equipment. If there is a diverse cooking line-up, use the worst-case scenario for the type of filter used.

Cooking Equipment Grease Emissions

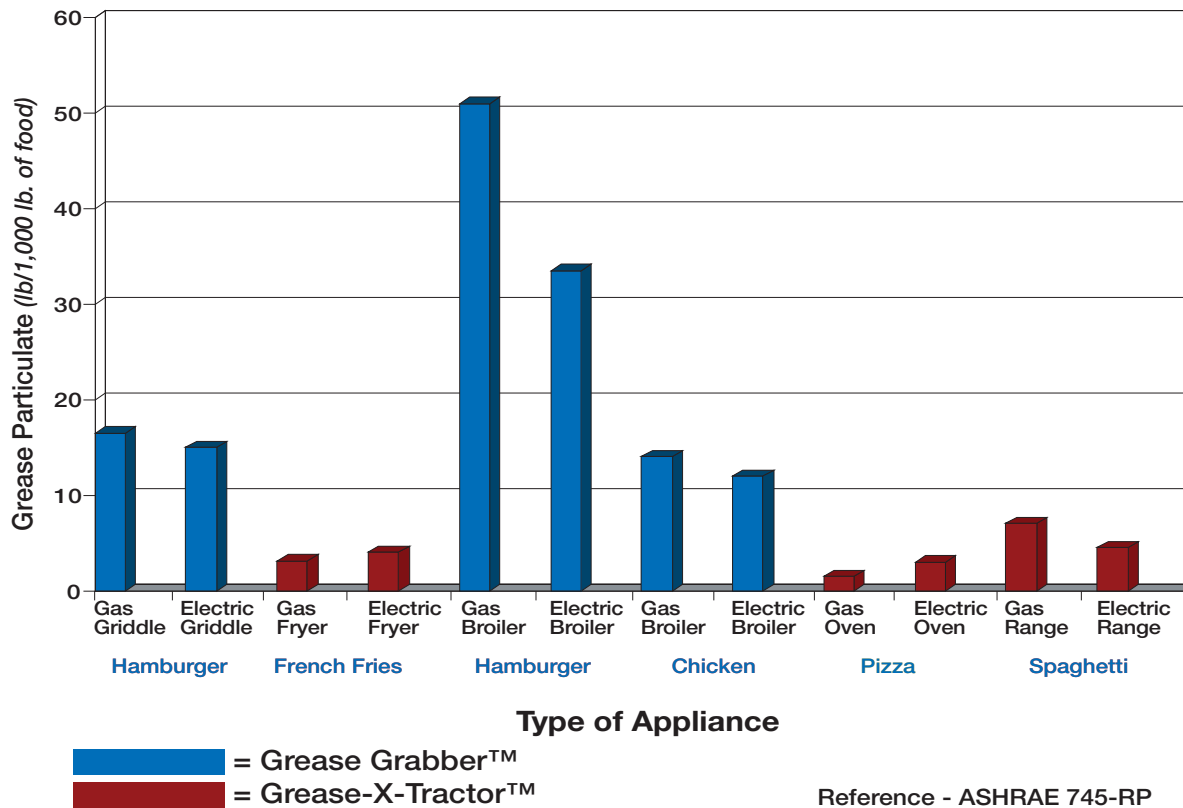

*Third-Party Grease Extraction Efficiency Verification

The charts on pages 21-24 show the amount of grease that is extracted by a typical baffle filter, Greenheck's Grease-X-Tractor and Grease Grabber filtration system. The charts also show the amount of grease that pass through the filter and into your exhaust duct, through your exhaust fan and onto your roof.

This data was gathered by a third-party testing agency while cooking beef patties on a griddle. The cooking of beef patties on a griddle yielded the largest mass of grease particles at ~18 microns in size and the smallest at ~0.2 microns in size (human hair ~100 microns).





The blue area represents the amount of grease that passed through the filter. The green area represents the amount of grease extracted by the filter. The more green area there was, the more grease that was extracted in the filter. The orange efficiency line shows the efficiency of the filter for a specific particle size.



Make-up air can be introduced several ways, including ceiling diffusers, through-the-hood with an integrated supply plenum or an external supply plenum. External supply plenums positioned around the perimeter of exhaust only hoods are a great alternative to integral supply plenums. Unlike integral supply plenums, they do not sacrifice valuable hood containment area. They can be retrofitted to almost any hood and are generally less expensive than integral plenums. Greenheck offers the following external supply choices: Air Curtain Supply Plenum (ASP), Horizontal Supply Plenum (HSP), Variable Supply Plenum (VSP), and the Back Supply Plenum (BSP).

Standard construction features:

- 18 gauge 430 stainless steel
- Easily removable perforated discharge panels (23% open area)
- Supply plenums are available in lengths from 3 to 16 feet where longer lengths require multiple plenums

Plenum Type	Discharge Opening (Inches)	Recommended Supply Rate (cfm/ft)	Recommended Application
 <p>Air Curtain Supply (ASP) 12 to 24 inch widths</p>	<p>12-inch: 10 24-inch: 22</p>	<p>12-inch: Up to 110 24-inch: Up to 145</p>	<p>All Conditions To minimize mixing with air in the space by distributing airflow at the hood, downward.</p>
 <p>Horizontal Supply (HSP)</p>	<p>15½</p>	<p>Up to 150</p>	<p>Tempered Air (Heated and Cooling)* Provides supply air to mix with room air.</p>
 <p>Back Supply (BSP)</p>	<p>6</p>	<p>Up to 145</p>	<p>Non-Tempered or Marginally Tempered Air Air is kept near hood to minimize mixing with air in the space.</p>
 <p>Variable Supply (VSP)</p>	<p>Face 8 Curtain 8</p>	<p>Face Up to 160 Curtain Up to 80</p>	<p>Non-Tempered or Marginally Tempered Air Air is kept near hood to minimize mixing with air in the space.</p>

* Climate determines tempering conditions.

Air Curtain Supply Plenum (ASP)

Air curtain supply plenums are typically used in non-tempered or heat-only applications, depending upon climate (can be used as an efficient method for spot-cooling).

- Air curtain supply plenums introduce the air near the hood to minimize mixing with air in the space
- A series of perforated panels evenly distribute air at lower discharge velocities which increase hood capture and containment
- Easy and flexible installation
- Mounted 14-20 inches above the bottom edge of the hood or flush with a drop ceiling
- External plenums can be placed on multiple sides of the hood to create a curtain of air on all exposed sides and increase the volume of air brought in at the hood
- The air curtain supply plenum is available in widths of 12 to 24 inches, in one inch increments.



Air Curtain Supply Plenum

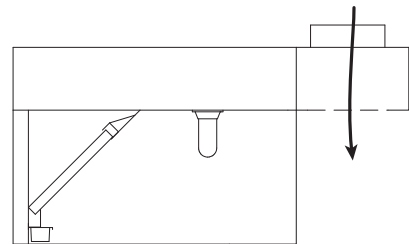

Split Air Curtain Supply Plenum

The optional split air curtain supply plenum (ASP) is an attractive method to provide make-up air and conditioned air through one plenum. Non-tempered make-up air is drawn into the hood, while the cooled conditioned air moves outward to provide spot cooling to the kitchen space.



Optional Split Air Curtain Supply Plenum shown with optional LED lights

Horizontal Supply Plenum (HSP)

Horizontal supply plenums are typically used in fully tempered air applications since the air will mix with the air in the surrounding space.

- Make-up air is introduced horizontally through the face of the external supply plenum via perforated panels in a manner that does not interfere with the cooking operations beneath the hood(s)
- Perforated panels are located on the face of the external supply plenum to limit the throw to within several feet of the hood(s) and maintain laminar flow
- Easy and flexible installation
- The HSP is typically mounted flush with the top of the hood
- The HSP is 12 inches wide by 14 inches high

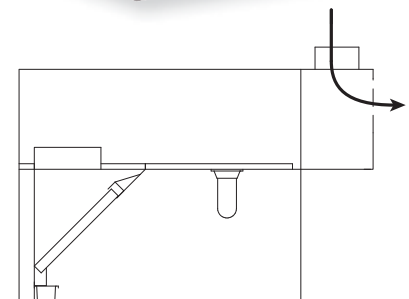

Variable Supply Plenum (VSP)

The variable supply plenum is a versatile plenum combining the features of the face and air curtain supply plenums.

- Make-up air is supplied horizontally through the face and vertically through the front perimeter via perforated panels in a manner that does not interfere with the cooking operations beneath the hood(s)
- Easy and flexible installation
- Manual damper is included in the plenum to modulate airflow between the face and air curtain allowing 0% to 50% through the air curtain and 50% to 100% percent through the face
- Best suited for cooler climates where outside air can be used to cool the kitchen (although either tempered or non-tempered air can be used depending on climate and comfort goals)
- The VSP is 12 inches wide by 18 inches high

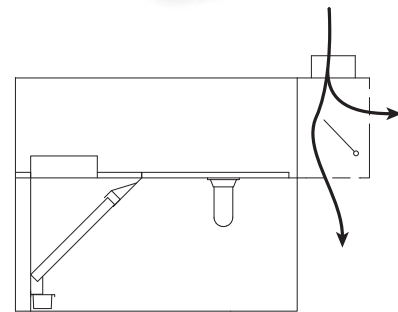

Back Supply Plenum (BSP)

Back supply plenums are typically used in non-tempered or marginally tempered applications. Also, these plenums are ideal for heating air during the colder months since hot air will rise from a low discharge position.

- An effective way to introduce make-up air into the kitchen is from the rear of the hood through a back supply plenum where the air is discharged behind and below the cooking battery (double layer of perforated panels allow for well-distributed low-velocity airflow)
- Back supply plenums also function as a backsplash panel and provide the proper clearance to limited combustibles needed in many installations to meet NFPA 96 standards
- Easy and flexible installation
- This plenum directs airflow through perforated panels behind and below the cooking equipment without affecting capture and containment, cooking surface temperature or pilot lights
- When using non-tempered air, utilizing low air velocities will keep the air near the hood
- These plenums are 6 inches deep, stretch the entire length of the hood and discharge at 31¼ inches above the finished floor

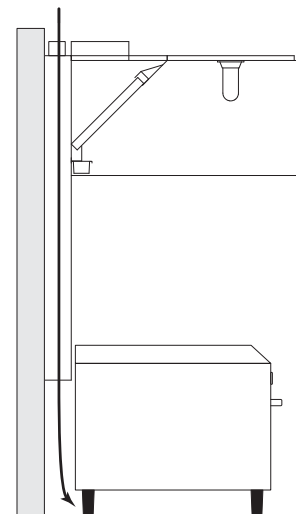

Ready for fire!

Cooking is the leading cause of residential building fires. An estimated average of 165,000 cooking fires occur annually, resulting in property loss, injuries and even death.

Residential buildings typically rely on portable fire extinguishers and sprinkler systems to protect property and occupants. Portable extinguishers require early use and manual intervention to contain fires, while sprinkler systems act as a final measure of protection.



The Fire Ready Hood is a dual purpose device. It is both a ventilation hood and a self-contained fire suppression system. The Fire Ready Hood is designed for use above residential style appliances in commercial settings, such as:

- Office lunchrooms
- Military housing
- Assisted living facilities
- Extended stay hotels
- Churches

How does it work?

The Fire Ready Hood monitors the hood temperature. In the event of a cooking fire, the Fire Ready Hood will:

- De-energize appliance using supplied the disconnect
- Signal an audible alarm
- Engage auxiliary building alarm contacts

If the hood temperature continues to climb, a fusible link will melt. This will release a wet chemical suppression agent through nozzles, suppressing the cooking fire.

- 30 and 36 inch widths
- UL300A approved
- Front recirculation or external venting
- Optional NFPA101 compliant accessories
- Gas, electric or dual utility appliance disconnects

The Fire Ready Hood model GRRS is equipped with standard features that add value while preventing cooking fires from getting out of control.

Feature	Benefit
Fusible Link	Reliable mechanical fire detection.
Appliance Disconnect	De-energizes appliance if hood temperature climbs too high.
Amerex® 660 Wet Chemical Agent	Quickly suppresses flames – cleans up with soap and water.
Audible Alarm	Alerts occupants of fire danger.
ECM Fan Motor	Adjustable fan speed for odor and sound control.

Amerex

Restaurant fires can be devastating. A fire can begin on an appliance, in the hood or ductwork, and quickly spread to the building. A pre-engineered fire suppression system is the first line of defense against a restaurant kitchen fire. Amerex has been in the fire protection industry since 1971 and has a reputation for excellence, customer service and innovation unsurpassed in the industry.



Quality is Behind the Diamond

Amerex KP Fire Suppression Systems

Appliance specific fire suppression is a wet chemical system to be used when the equipment placement is known and expect few, if any, changes. Nozzles are selected and aimed at specific hazards on each appliance. The chemical agent itself a low pH that's non-corrosive to stainless steel which can be safely cleaned up with water and a sponge.

Amerex Zone Defense Fire Suppression Systems

The full flood/overlapping restaurant fire suppression systems were developed to solve the real world problem of how to protect a kitchen where the appliances are moved around, rolled in and out for cleaning, or replaced with different appliances to accommodate changing menus. These systems are also cost effective with medium and heavy duty cooking lines requiring greater protection.

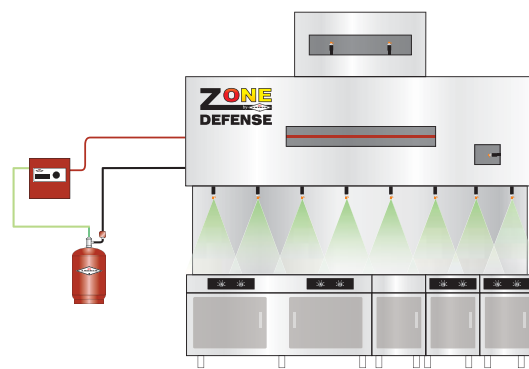
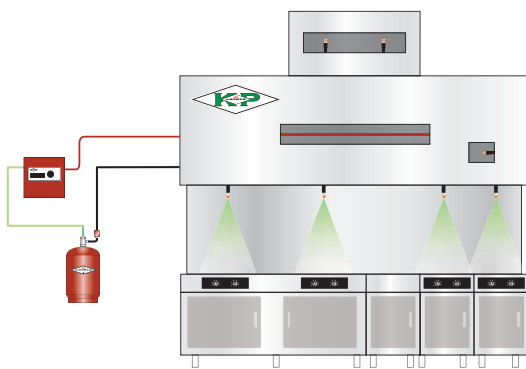

Features and Benefits

- Stainless agent tank enclosures – provide a professional look
- Fusible link or pneumatic tubing detection - flexibility to suit design requirements
- Additional switches (two SPDT is standard) – for additional equipment shutdown as required
- Additional pull stations (one is standard) – for large rooms with multiple exits
- Metal blow off caps - for high heat applications
- Horn strobes - for visual and audible emergency notification
- Low pressure alarm – helps prevent a false discharge due to pressure loss
- K-Class handheld extinguishers – to meet NFPA 96 code requirements

The Restaurant Fire Suppression System is constructed in compliance with the following:

- UL/cUL Listed per UL 300 fire test specifications
- New York City Department of Buildings (MEA)
- Meets requirements of NFPA 96 (Standard for the Installation of Equipment for the Removal of Smoke and Grease-Laden Vapors from Commercial Cooking Equipment)
- Meets requirements of NFPA 17A (Standard on Wet Chemical Extinguishing Systems)
- ISO 9001:2000 and ISO 14001:2004 certified

Ansul

Ansul has been protecting restaurants since 1962 and is one of the industry leaders in fire suppression systems,

Ansul led the industry at a time when kitchen fires were a leading cause of restaurant loss, and their continued advancements in technology and design have made Ansul the number one foodservice fire protection solution in the world.



Ansul R-102 Fire Suppression System



In an appliance specific fire system, the nozzles and placement are chosen for the type of cooking equipment it needs to protect. This is the most cost-effective system, as only the appliances that need protection are covered.

Ansul Piranha Fire Suppression System



Dual agent fire suppression systems combine water and chemical agent to suppress the fire. The agent is discharged first, suppressing the fire, and water follows to cool the hazard and prevent reflash. Dual agent systems can be either appliance specific or full flood.



Options and Accessories

- Stainless tank enclosures – provide a professional look
- Flexible agent distribution hose so appliances can be rolled out for cleaning
- Additional switches (two SPDT is standard) – for additional equipment shutdown as required
- Additional pull stations (one is standard) – for large rooms with multiple exits
- Metal blow off caps - for high heat applications
- Horn strobes - for visual and audible emergency notification
- K-Class handheld extinguishers – to meet NFPA 96 code requirements

The Restaurant Fire Suppression System is constructed in compliance with the following:

- UL/cUL Listed per UL 300 fire test specifications
- New York City Department of Buildings (MEA)
- Meets requirements of NFPA 96 (Standard for the Installation of Equipment for the Removal of Smoke and Grease-Laden Vapors from Commercial Cooking Equipment)
- Meets requirements of NFPA 17A (Standard on Wet Chemical Extinguishing Systems)
- ABS - American Bureau of Shipping
- UL Standard 2092 Listed (Piranha®)



Building Value in Air

Greenheck delivers value to mechanical engineers by helping them solve virtually any air quality challenges their clients face with a comprehensive selection of

top quality, innovative air-related equipment. We offer extra value to contractors by providing easy-to-install, competitively priced, reliable products that arrive on time.

And building owners and occupants value the energy efficiency, low maintenance and quiet dependable operation they experience long after the construction project ends.

Our Commitment

As a result of our commitment to continuous improvement, Greenheck reserves the right to change specifications without notice.

Specific Greenheck product warranties are located on greenheck.com within the product area tabs and in the Library under Warranties.



Prepared to Support
Green Building Efforts

